

# Embracing Change through Innovation



# contents

notice of annual general meeting	2
statement accompanying notice of annual general meeting	4
corporate information	5
board of directors	6
profile of directors	7
corporate structure	10
executive chairman's statement	11
ceo's review	14
corporate governance statement	17
statement of internal control	23
audit committee report	24
directors' responsibility statement	28
financial statements	29
list of properties	62
analysis of shareholdings	65
proxy form	

# notice of annual general meeting

2

BSL CORPORATION BHD • ANNUAL REPORT 2005

**NOTICE IS HEREBY GIVEN** that the Second Annual General Meeting of the Company will be held at Subang 2, Sheraton Subang Hotel, Jalan SS12/1, 47500 Subang Jaya, Selangor Darul Ehsan on Wednesday, 22 February 2006 at 10.30 a.m. to transact the following business:

## Agenda

### As Ordinary Business

1. To receive the Audited Financial Statements for the financial year ended 31 August 2005 together with the Reports of the Directors and Auditors thereon. Resolution 1
  
2. To elect the following Directors who retire pursuant to Article 83 of the Company's Articles of Association:
  - (i) Ngiam Tong Kwan Resolution 2
  - (ii) Ngiam Tee Wee Resolution 3
  - (iii) Dato' Hamzah Bin Mohd Salleh Resolution 4
  - (iv) Dato' Kalsom Abdul Rahman Resolution 5
  - (v) Ngiam Tee Yang Resolution 6
  - (vi) Teh Yoon Loy Resolution 7
  - (vii) Yukihiro Eguchi Resolution 8
  - (viii) Gan Leng Swee Resolution 9
  - (ix) Chong Ai Wan Resolution 10
  
3. To approve Directors' Fees for the financial year ended 31 August 2005. Resolution 11
  
4. To re-appoint Messrs Deloitte KassimChan as Auditors of the Company and to authorise the Directors to fix their remuneration. Resolution 12

### As Special Business

5. To consider and if thought fit, to pass, with or without modifications, the following Ordinary Resolution:

"THAT pursuant to Section 132D of the Companies Act, 1965, the Directors of the Company be, and are hereby, empowered to issue shares in the Company at any time and upon such terms and conditions and for such purposes as the Directors may in their absolute discretion deem fit, provided that the aggregate number of shares issued pursuant to this resolution in any one financial year does not exceed 10% of the issued share capital of the Company for the time being, and that the Directors be, and are also empowered, to obtain approval for the listing of, and quotation for, the additional shares so issued on Bursa Malaysia Securities Berhad, and that such authority shall continue to be in force until the conclusion of the next Annual General Meeting of the Company unless revoked or varied by the Company at a general meeting."

Resolution 13

By Order of the Board

**Ng Yen Hoong** (LS 008016)  
**Lim Poh Yen** (MAICSA 7009745)  
Company Secretaries

Petaling Jaya  
27 January 2006

## NOTES:

### 1. Notes on Appointment of Proxy

- (a) A member (other than an Authorised Nominee as defined under the Securities Industry (Central depositories) Act 1991) entitled to attend and vote at the Meeting is entitled to appoint a maximum of two Proxies to attend and vote on his (her) behalf. A proxy may but need not be a member of the Company and the provisions of Section 149(1)(b) of the Companies Act, 1965 shall not apply to the Company.
- (b) Where a member appoints two (2) Proxies, the appointment shall be invalid unless he (she) specifies the proportions of his (her) holdings to be represented by each Proxy.
- (c) The Proxy Form shall be signed by the appointor or his (her) attorney duly authorized in writing or, if the member is a corporation, must be executed under its common seal or by its duly authorized attorney or officer.
- (d) The instrument appointing a Proxy must be deposited at the registered office at Level 14, Uptown 1, No. 1, Jalan SS21/58, Damansara Uptown, 47400 Petaling Jaya, Selangor Darul Ehsan, not less than 48 hours before the time for the meeting or at any adjournment thereof.

### 2. Explanatory Notes on Special Business

The Ordinary Resolution proposed under Resolution 13, if passed, will empower the Directors of the Company to allot and issue new ordinary shares up to an amount not exceeding 10% of the issued share capital of the Company for such purposes as the Directors consider would be in the interest of the Company. This authority will commence from the date of this Annual General Meeting and unless revoked or varied by the Company at a general meeting, will expire at the next Annual General Meeting.

# statement accompanying notice of annual general meeting

4

BSL CORPORATION BHD • ANNUAL REPORT 2005

## (1) Venue, Date and Time of the 2nd Annual General Meeting

The details of the Second Annual General Meeting of the Company:

Venue: Subang 2  
Sheraton Subang Hotel  
Jalan SS12/1  
47500 Subang Jaya  
Selangor Darul Ehsan

Date: 22 February 2006 (Wednesday)

Time: 10.30 a.m.

## (2) Directors Standing for Re-election

The name of Directors who are standing for election or re-election pursuant to Article 83 of the Company's Articles of Association:

- (i) Ngiam Tong Kwan
- (ii) Ngiam Tee Wee
- (iii) Dato' Hamzah Bin Mohd Salleh
- (iv) Dato' Kalsom Abdul Rahman
- (v) Ngiam Tee Yang
- (vi) Teh Yoon Loy
- (vii) Yukihiro Eguchi
- (viii) Gan Leng Swee
- (ix) Chong Ai Wan

## (3) Attendance of Directors at Board Meetings

The attendance record at Board Meetings can be found on page 17 and other details of the abovenamed Directors can be found in the Profile of Board of Directors in this Annual Report.



## Board of Directors

### **Ngiam Tong Kwan**

*Executive Chairman*

### **Ngiam Tee Wee**

*Chief Executive Officer/Executive Director*

### **Ngiam Tee Yang**

*Executive Director*

### **Teh Yoon Loy**

*Executive Director*

### **Yukihiro Eguchi**

*Executive Director*

### **Dato' Hamzah Mohd Salleh**

*Non-Independent Non-Executive Director*

### **Dato' Kalsom Abdul Rahman**

*Independent Non-Executive Director*

### **Gan Leng Swee**

*Independent Non-Executive Director*

### **Chong Ai Wan**

*Independent Non-Executive Director*

## Audit Committee

### **Gan Leng Swee**

*Chairman, Independent Non-Executive*

### **Ngiam Tee Wee**

*Chief Executive Officer*

### **Chong Ai Wan**

*Independent Non-Executive Director*

## Company Secretaries

**Ng Yen Hoong** (LS 008016)

**Lim Poh Yen** (MAICSA 7009745)

## Registered Office

Level 14, Uptown 1  
No. 1, Jalan SS 21/58  
Damansara Uptown  
47400 Petaling Jaya  
Selangor Darul Ehsan

Tel: 03-7725 2888

Fax: 03-7725 7791

## Registrars

### **PFA Registration Services Sdn Bhd**

Level 13, Uptown 1  
No. 1, Jalan SS 21/58  
Damansara Uptown  
47400 Petaling Jaya  
Selangor Darul Ehsan

Tel: 03-7725 4888

Fax: 03-7722 2311

## Auditors

### **Deloitte KassimChan** (AF 0080)

Level 19, Uptown 1  
No. 1, Jalan SS 21/58  
Damansara Uptown  
47400 Petaling Jaya  
Selangor Darul Ehsan

Tel: 03-7723 6500

Fax: 03-7726 3986

## Principal Bankers

### **Citibank Berhad**

### **OCBC Bank (Malaysia) Berhad**

## Stock Exchange Listing

Second Board of the  
Bursa Malaysia Securities Berhad



**1 Ngiam Tong Kwan**

*Executive Chairman*

**2 Ngiam Tee Wee**

*Chief Executive Officer/Executive Director*

**3 Ngiam Tee Yang**

*Executive Director*

**4 Dato' Kalsom Abdul Rahman**

*Independent Non-Executive Director*

**5 Teh Yoon Loy**

*Executive Director*

**6 Yukihiro Eguchi**

*Executive Director*

**7 Dato' Hamzah Mohd Salleh**

*Non-Independent Non-Executive Director*

**8 Gan Leng Swee**

*Independent Non-Executive Director*

**9 Chong Ai Wan**

*Independent Non-Executive Director*

**Ngiam Tong Kwan***Executive Chairman and founder of the Group*

Aged 56, Malaysian. Appointed to the Board on 28 April 2005, he started his career as an apprentice tool maker in 1966 at Perusahaan Winco Sdn. Bhd. Five (5) years later, he was promoted to Production Supervisor where he not only supervised employees in the production department but was also involved in production and material planning. He was later promoted to Sales Manager. In 1978, he decided to venture out on his own and set up Ban Seng Lee Industries Sdn Bhd, guiding it through steady growth over the years. He is also the director and co-founder of Unique, Crestronics and Kotamech.

He provides the strategic business direction for the Group's various businesses and is responsible for overall management of the Group.

He is a member of the Remuneration Committee of BSL

He is the father of Ngiam Tee Wee, the CEO of BSL.

---

**Ngiam Tee Wee***Chief Executive Officer**Bachelor of Land Surveying, University of Melbourne, Australia*

Aged 37, Malaysian. Appointed to the Board on 28 April 2005, he started his career in 1993 as Factory Manager of Unique, a subsidiary of BSL. In 1995, he was transferred to BSLI as an Operations Manager. In 1998, one year after he completed his ISO 9000 Lead Assessor training, he led BSLI to ISO 9002 certification. He was promoted to General Manager in 2000 where his responsibilities included overseeing daily operations, sales and marketing, R&D and engineering. He was made the managing director of BSLI and CEO of BSL in 2005.

He assists the Executive Chairman in the day-to-day operations of the Group. He is also responsible for business development as well as the implementation of corporate strategies. He is a member of the Audit Committee and the Risk Assessment & Monitoring Committee.

He is the adopted son of the Executive Chairman, Ngiam Tong Kwan.

---

**Ngiam Tee Yang***Executive Director**Bachelor of Engineering, National University of Singapore  
Diploma in Sales & Marketing Management, Temasek Polytechnic*

Aged 40, Malaysian. Appointed to the Board on 28 April 2005, he started work after graduation in 1989 as a Management Trainee in Miyoshi Precision (S) Pte. Ltd., a Japanese precision metal stamping company in Singapore. He was attached to different departments holding various positions such as the Assistant Manager of purchasing department and Sales Manager. He joined BSLI as the Business Development Manager in 1992. In 1999, he was appointed the Deputy Managing Director for Crestronics. His duties include managing the day-to-day operations and business development for Crestronics. He was made the Managing Director of Crestronics in year 2005.

He is the nephew of the Executive Chairman, Ngiam Tong Kwan and natural brother of the CEO Ngiam Tee Wee.

---

**Teh Yoon Loy***Executive Director**Degree in Business Administration, Louisiana State University, USA*

Aged 48, Malaysian. Appointed to the Board on 28 April 2005. He is the Managing Director of Unique, responsible for business development and overall performance of Unique. He started his career after his graduation in 1982 as a credit and marketing officer with Sincere Leasing Sdn. Bhd. He joined BSLI as a finance manager in 1984 and in 1989 he was appointed a Director of Unique.

He is the brother-in-law of the Executive Chairman, Ngiam Tong Kwan.



## **Yukihiro Eguchi**

*Executive Director*

*Graduate of Tokyo Technical High School*

Aged 43, Japanese. Appointed to the Board on 28 April 2005, he is also the Operations Director of Crestronics. Mr Eguchi joined his family-owned company Bright Trading Corporation in Tokyo after graduation in 1981, as an Automotive Mechanical Engineer. In 1986, he joined an American audio-video company, SounDesign Corporation, Tokyo Branch as an Engineer. During this time, he travelled frequently to Korea, and was stationed in Taiwan from 1988 to 1991.

In 1992, he joined New Tech Corporation, Tokyo as an Engineer in the R&D department and was transferred to Nouveau Tech (M) Sdn. Bhd., the Malaysian factory of New Tech Corporation in 1994, as General Manager of the QC department. In 1999, he joined and invested in Crestronic.

As Operations Director of Crestronics, he is responsible for the overall management of Crestronics.

He has no family relationship with any Director and/or major shareholders of BSL.

---

## **Dato' Hamzah Mohd Salleh**

*Non-Independent Non-Executive Director*

*Diploma in Management, Malaysian Institute of Management*

*Masters in Business Administration, University of Bath, UK*

Aged 57, Malaysian. He was appointed to the Board on 28 April 2005. Dato' Hamzah was an Audit Assistant with PricewaterhouseCoopers (formerly known as Price Waterhouse & Co.) from 1969 to 1975 and worked for five (5) years as Finance and Administration Manager in Pillar Naco Malaysia Sdn. Bhd., which deals with architectural metal fabrication. From 1980 to 1993, he held various senior management positions in Pemas Sime Darby Group and the Sime Darby Group of companies.

Presently, he is the Chief Executive Officer of Spanco Sdn. Bhd., a fleet management specialist. He has been the Director of PDZ Holdings Berhad since 1996 and Furniweb Industrial Products Berhad since 2003 and Focus Dynamics Technologies Berhad since 2005. In addition, he is a director of various other private companies.

He also sits on the Board of Ban Seng Lee Industries Sdn Bhd.

He is the member of the Remuneration Committee and the Nomination Committee of BSL

He has no family relationship with any Director and/or major shareholders of BSL.

---

## **Dato' Kalsom Abdul Rahman**

*Independent Non-Executive Director*

*Bachelor of Economics (Honours), University Malaya*

*Masters in Business Administration (Finance) University of Oregon, USA*

Aged 57, Malaysian. She was appointed to the Board on 28 April 2005. Dato' Kalsom served in various capacities in the Ministry of International Trade and Industry (MITI), both at Headquarters and overseas offices and her last post being, the Deputy Secretary General of MITI.

She currently sits on the Board of Malaysian Industrial Development Finance (MIDF) Berhad, Chemical Companies of Malaysia Berhad (CCM), Malaysian International Shipping Corporation Berhad (MISC), Lion Forest Industries Berhad (LFIB), Hyundai-Sime Darby Berhad and other private limited companies.

She is also currently the Chairman of Small and Medium Industries Development Corporation (SMIDEC) and the Chairman of the Executive Committee of Invest-In-Penang Berhad, a state agency responsible for the promotion of investments and business in Penang.

She is also a director of Unique Forging & Components Sdn Bhd.

She is the Chairman of the Remuneration Committee and member of Nomination Committee of BSL.

She has no family relationship with any Director and/or major shareholders of BSL.

**Gan Leng Swee**

*Independent Non-Executive Director  
Bachelor of Economics, University of Malaya*

Aged 54, Malaysian. He was appointed to the Board on 28 April 2005. Upon graduation in 1974, joined Citibank N.A. as a trainee officer and subsequently moved up to Assistant Vice President for the Institutional Banking Group. He joined the MBF Group in 1984 as an Associate Director in Dow MBF Ltd. Hong Kong and later became the General Manager of MBF Leasing Sdn. Bhd. From 1986 to 1990, he served in various senior credit positions at the Oriental Bank, Kuala Lumpur and Overseas Union Bank, Singapore.

He ventured into stockbroking with Singapore-based G.K. Goh (Stockbrokers) Pte. Ltd., as a dealer's representative for institutional sales for a year before setting up his own management consultancy practice involving business process re-engineering, mergers and acquisitions and information technology ventures. In 1998 he was contracted to Kepple Bank Philippines for a year as the Chief Operating Officer

He is currently also the Director of Fututech Bhd and Watta Holdings Bhd and Chairman of their respective Audit Committees.

He is the Chairman of the Audit Committee, Nomination Committee and Risk Assessment & Monitoring Committee of BSL.

He has no family relationship with any Director and/or major shareholders of BSL.

---

**Chong Ai Wan**

*Independent Non-Executive Director  
Bachelor of Commerce (Accounting and Finance), University of Western Australia  
Masters in Business Administration (Techno & Entrepreneurship) University Technology Malaysia*

Aged 34, Malaysian. Appointed to the Board on 28 April 2005, Chong started her career in 1996 as a tax consultant assistant in KPMG Tax Services Sdn. Bhd. In 1997, she joined Messrs. Ong Boon Bah & Co. as an auditor where she stayed for 3 years. In 2001, she joined Watta Holdings Berhad as an Assistant Manager of the internal audit department. Currently, she is a business advisor for two private limited companies.

She is a Chartered Accountant, and is a member of the Malaysia Institute of Accountants. She is also a Certified Practicing Accountant with the CPA Australia and a Certified Internal Auditor with the Institute of Internal Auditors (U.S.A).

Chong is a member of the Audit Committee and Risk Assessment & Monitoring Committee of BSL.

She has no family relationship with any Director and/or major shareholders of BSL.

---

**Note:**

- a: None of the directors have any conviction for offence (other than traffic offences) within the past 10 years.
- b: Save as disclosed above, none of the directors have any family relationship with any director and/or major shareholder of the Company
- c: None of the directors have any conflict of interest with the Company

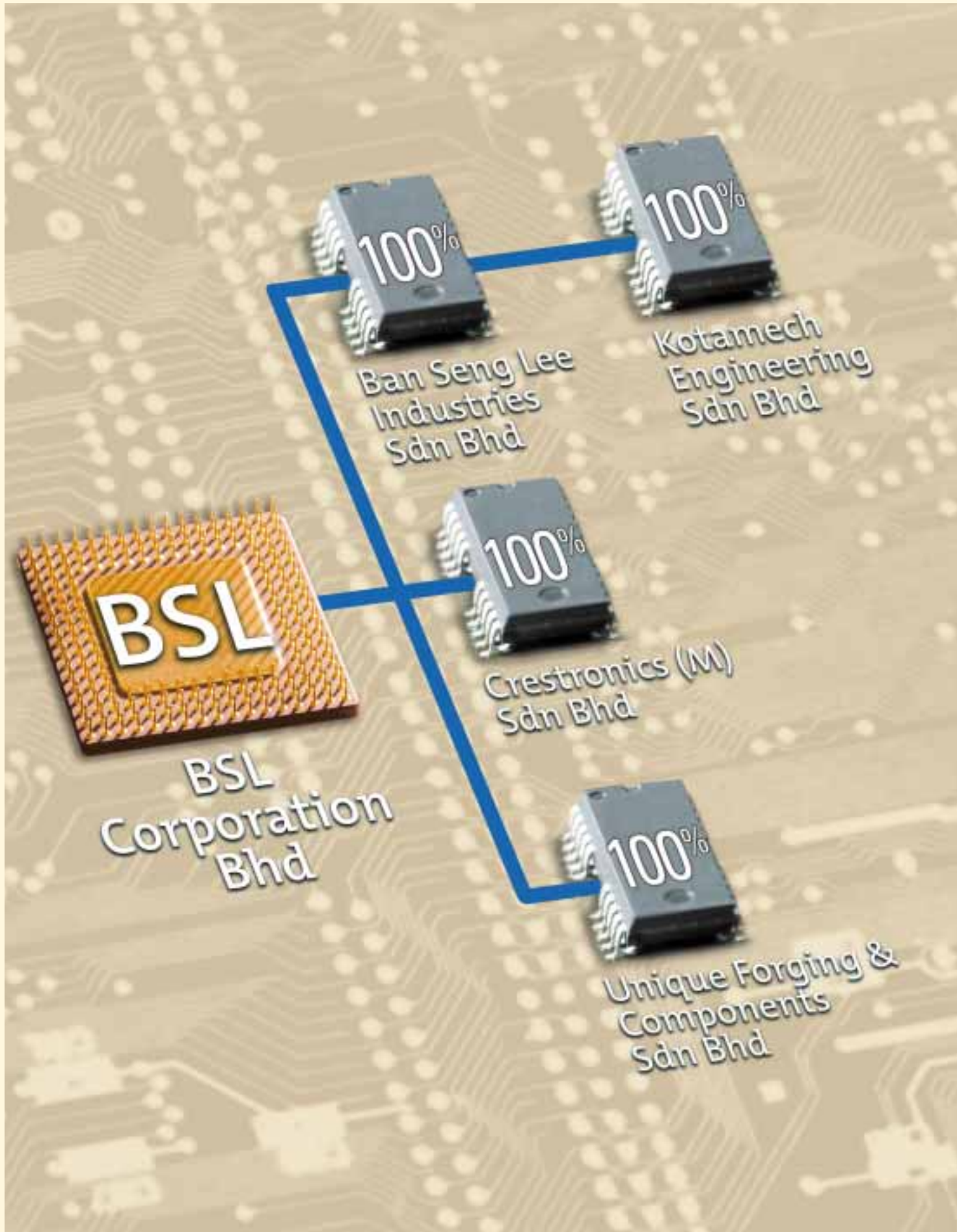

Dear Shareholders,

The BSL Group of Companies achieved a major corporate milestone for the financial year (FY) ended 31 August 2005. The Group's restructuring scheme received the requisite approvals from regulatory authorities, including the Securities Commission, which paved the way for the flotation and listing of our shares on the Malaysian bourse.

The initial public offering ("IPO"), which involved a public issue of 20.373 million shares and an offer for sale of 6.988 million new shares, was launched after the financial year end, on 30 September 2005. BSL made its debut on Bursa Malaysia on 15 November 2005.

This is BSL's first annual report as a member of Bursa Malaysia, and on behalf of the Board of Directors, I am pleased to be presenting the financial results for the financial year ended 31 August 2005.

## Financial Review

A review of the Group's financial performance against the previous year is not available as the restructuring was only completed in April 2005. I have used the proforma figures of FY2004 purely for illustrative purposes.

For the 12 months ended 31 August 2005, our Group achieved a proforma revenue of RM85.99 million which was 7.41% higher than the RM80.06 million in FY2004.

The profit before tax for the Group improved to RM11.83 million, 18.06% higher than the RM10.02 million in FY2004, while profit after tax and after netting out pre-acquisition profit amounted to RM3.39 million.

Based on the weighted average number of ordinary shares in issue of 24.64 million shares, earnings per share came to 14 sen per share; while net tangible assets per share amounted to 59 sen based on the enlarged issued share capital of 73.93 million shares as at 31 August 2005.

## Operational Performance

The improved financial performance of the Group can be attributed to the Group's ability to secure orders from customers, both locally as well as internationally. Our subsidiaries grew by tapping their existing customer base, value-adding to their various processes, and securing new multinational corporation customers in all three business activities of the Group.

A more detailed review of the business segment performances is out in pages 45 to 46.

## Dividend

In accordance with our prospectus issued in conjunction with the IPO, the Board is not recommending any dividend payment for the financial year under review.



## Corporate Governance

The Board recognises the importance of ensuring that the highest standards of corporate governance are practised throughout the Group to protect and maximise stakeholders' value and to safeguard the Group's assets.

The Board has also resolved that the Group must continually improve on the Group's best practices and adhere to the recommendations of the Malaysian Code on Corporate Governance.

The level of compliance is set out in our Statement of Corporate Governance in pages 17 to 22.



## Current Year Outlook

The Government in its 2006 Budget proposals has projected Malaysia's Gross Domestic Product to expand by 5.5% despite the challenges posed by the sharp increases in oil prices and the less accommodative monetary stance of developed countries.

The Government's policy of continuing to provide a business-friendly environment while encouraging the private sector to diversify into new economic activities that offer growth potential, augurs well for us.

In this regard, BSL is actively identifying areas, which it can build on its competitive advantage, and expand its value-adding manufacturing services beyond high-tech electronic and electrical products to include such items as automotive parts and components and digital mobile phones and PDAs.

The Board also believes the Group is able to compete effectively not only for Malaysian-based OEM businesses but also for regional contracts from multinational corporations. The latter is a growing trend among multinational corporations who are intent on gaining market share in the Asian region, undoubtedly one of the fastest growing regions in the world.

With our proven track record and reputation as a reliable and high-quality third party manufacturer for several blue-chip, regional, electronic MNCs, some of which have been BSL's clients for 16 to 27 years, we are well-placed to tap these outsourcing opportunities.





In addition, the Group has in-house design and prototyping, and Development & Design ("D&D") capabilities; which are led by an experienced and innovative management team, which are supported by highly skilled employees. Our team is ready to embrace whatever changes necessary to enable the Group to harness these opportunities for growth.

Notwithstanding these, the Group's core businesses are expected to continue to expand at a healthy pace, driven by domestic growth as well as regional demand fuelled by the regional economic expansion.

## Appreciation

On behalf of the Board, I would like to thank our valued customers, suppliers and shareholders for their continued support throughout the financial year. The Board would also like to place on record our appreciation to our dedicated staff and employees for their commitment and hard work.

### **Ngiam Tong Kwan**

*Executive Chairman*

27 January 2006



## Strategic Partnerships with Multinational Corporations

It has been a hectic year for BSL, particularly at the corporate front, where the Group embarked on a corporate restructuring scheme. The completion of the scheme on 28 April 2005 resulted in a Group with strategic and competitive advantages in the electrical, electronic and mechanical products industries and paved the way for the Company's listing on the Second Board of Bursa Malaysia.

The Company's three (3) subsidiaries are involved in different but complementary core activities whose combined capabilities make BSL a strategic manufacturing partner for multinational corporations:

1. Ban Seng Lee Industries Sdn Bhd ("BSLI"), has an established reputation as a reliable and high quality solutions provider of precision metal stamping, mould and die fabrication.
2. Crestronics (M) Sdn Bhd ("Crestronics"), while only established nine (9) years ago, has transformed itself as a preferred one-stop outsourcing partner for the assembly of a wide range of printed circuit boards for electrical appliances.
3. Unique Forging & Components Sdn Bhd ("UFC"), whose core competency is fabrication and forging of base metal components, was established 15 years ago. Today it is one of Malaysia's leading companies in the sector, with capabilities to handle steel forging to meet the growing demand for sophisticated automotive and industrial component parts.



I am pleased to present here, a review of the Group's operations. A more detailed review of the segmental results is set-out in pages 45 to 46.

### Expansion of Production Facilities & Capabilities

BSLI's newly acquired factory, located near the existing precision stamping operation in Taman Bukit Idaman, Selayang, commenced operations in September 2004. The new plant focussed on the provision of silk screen printing for stamped metal components to further enhance the range of value-added services to its customers, particularly electronic and electrical MNCs.

As part of the Group's continuous programme of cost reduction and improve efficiency, BSLI implemented the Toyota Production System ("TPS") in collaboration with a client who is a major automotive component manufacturer. TPS is a sophisticated production system which focuses on the elimination of process waste, thereby improving efficiency and reducing costs.

At Crestronics' factory in Meru, Klang, the facilities and machinery are constantly being upgraded, to meet exacting production requirements of our clients, all of whom are invariably manufacturers of electronics and electrical products.

During the year, Crestronics has introduced the Centralized Networking Inspection whereby quality inspection of all Surface Mount Technology ("SMT") lines are linked and judged by qualified inspectors. In addition, In-Line Automated Optical Inspection was incorporated to each SMT line to ensure all components on the printed circuit boards are properly mounted. The Manual Insertion Conveyors were also shortened, enabling us to achieve better efficiency.

UFC, which has an established track record in the design and fabrication of multi-dimensional moulds for the forging industry, also expanded its production facilities to cater for the increasingly more sophisticated components required by the automotive and manufacturing industries.

The transfer of technology for fabricating welding moulds using the Argon Welding Machine from Taiwan have enhanced our productivity due to the fact that this type of mould are harder and stronger; and its life span is 3-4 times longer than the conventional mould. Furthermore, our success in fabricating the double cavity mould for our customers will double our production and reduce the use of raw material.

In addition to steel forging facilities, UFC will soon start producing its own products, comprising of hydraulic fitting, hexagonal nuts and bolts, for the industrial sector. These value added products will enhance our sales and profits and position UFC as a major producer of finished components part in this region.

During the year, BSLI became the second subsidiary to enjoy the Licensed Manufacturing Warehouse ("LMW") status, the first being Crestronics. This status has further facilitated business with export orientated companies.



### International Certification and Design & Development ("D&D") Activities

The Group achieved another milestone in its pursuit of internationally recognised quality. BSLI was accorded the BS EN ISO 14001:2004 certification from the National Quality Assurance Limited; and Crestronics was awarded the MS ISO14001:1997 Environmental Management Systems certification from SIRIM QAS International Sdn Bhd.

The Group is committed to continuously improve its Environmental Management Systems and to meeting all local and international regulations on nature and environmental impact and the fulfilment of requirements from customers.

In addition, UFC was also on 23 November 2005 awarded the ISO 9001:2000 Quality Management System certification from SIRIM QAS International Sdn Bhd.

The achievement of these international certifications affirms our commitment towards providing services of international standards to our MNC customers.

BSL will continue to strengthen its D&D activities in order to stay ahead of competition. Among the D&D activities currently being developed, are new manufacturing processes that are more efficient, new tooling designs that would increase productivity and efficiency, and testing for substitute materials which are more cost effective.





## Development of Human Capital

The success of BSL is largely due to the contribution of its well-skilled and experienced workforce, whose commitment and dedication have helped the Group to stay competitive.

The Group will continue to adopt its policy of nurturing talents, through continuous training and education, with special emphasis on programmes that would enhance design, engineering and technical skills of its team.

## Market & Business Development

All three subsidiaries, with their core competencies and capabilities, provide the foundation and building blocks for the Group to expand into more complex and precise higher value-added products, an area which the Group is actively identifying opportunities.

BSL's principal customers are MNCs based in Malaysia with their headquarters located mainly in Japan and Korea, who are increasingly outsourcing manufacturing activities to third parties that offer competitive edge.

The Group is well placed to capitalise on such outsourcing opportunities flowing from its existing customer base, not only because of its manufacturing and D&D capabilities but also because of the strategic partnerships that have been developed and nurtured over many years.

The Group will also be cautiously exploring regional opportunities arising from the changing manufacturing and production trends in the electronics and automotive industries.

Last, but not least, the Group remains committed to its goal of being a market leader among its peers, and to achieve this, we strongly believe we must "embrace change through innovation".

### **Ngiam Tee Wee**

*Chief Executive Officer*

27 January 2006



The Board of BSL Corporation Berhad is of the view that good corporate governance is fundamental for the protection and enhancement of shareholders' value. It has therefore, taken steps to ensure that the highest standards of corporate governance are practiced throughout the Group.

The Board wishes to report that in compliance with the Malaysian Code of Corporate Governance and the Best Practices set out in the Code, the following have been implemented and put in practice.

## 1. Board of Directors

### a. Composition of the Board and Board Balance

The Group is led and supervised by an effective Board, comprising five (5) executive directors, one (1) non-independent non-executive director and three (3) independent non-executive directors. This complies with paragraph 15.02 of the Listing Requirements of Bursa Malaysia Securities Berhad which requires at least three (3) or one third of the Board of the Company are independent directors.

The Board composition brings together an extensive pool of experience in the technical, financial, business and government sectors, in particular, the independent directors bring to the Board deliberations invaluable experience on issues of business strategy and resource allocation.

The profiles of the Directors are presented in pages 7 to 9.

### b. Duties & Responsibilities

The Board assumes full responsibility for the overall performance of the Company and the Group. However, it is the five (5) Executive Directors who take on the primary responsibility of managing the Group's business and meeting the corporate objectives.

The Executive Chairman is primarily responsible for the orderly conduct and effectiveness of the Board. Together with the Chief Executive Officer, they are responsible for the day to day running of the business, implementation of the Board policies and making operational decision. There is a clear division of responsibilities between the Executive Chairman and Chief Executive Officer to ensure a balance of power and authority within the Group.

### c. Meetings

The Board endeavors to meet at least four (4) times a year, with additional meetings to be convened when necessary. No meeting was held during the financial year ended 31 August 2005. However, two Board of Directors' Meeting had been held on 20 October 2005 and 23 December 2005 which were attended by all the Board of Directors to review and approve the quarterly financial results for the period ended 31 August 2005 and the Audited Financial Statements for the year ended 31 August 2005.

### d. Supply of Information

The Directors have full and unrestricted access to all information within the Group and such information are furnished in a form and quality that is required by them to discharge their duties concerning the state of the business and performance before each Board Meeting.

The Directors also have access to the services of the Company Secretaries who have ensured that all appointments were properly made and all statutory obligations as well as obligations arising from the listing rules of the exchange or other regulatory requirements are continuously met.

## 1. Board of Directors (continued)

### e. Board Committees

The Board had delegated specific responsibilities to four (4) committees all of which have written terms of reference approved by the Board. These committees have the authority to examine particular areas and report back to the Board with their findings and recommendations. The ultimate responsibility for the final decision on all matters lies with the Board. These committees are:

#### (i) *Audit Committee*

The Audit Committee was established on 13 July 2005. It comprises two (2) independent non-executive directors and the Chief Executive Officer. The Audit Committee Report for the financial year ended 31 August 2005 is detailed on pages 24 to 27 of this Annual Report.

#### (ii) *Remuneration Committee*

The Remuneration Committee was set up on 20 October 2005. The members of the Remuneration Committee are as follows:

1. **Dato' Kalsom Binti Abdul Rahman**  
*(Chairman) (Independent Non-Executive Director)*
2. **Dato' Hamzah Bin Mohd Salleh**  
*(Non-Independent Non-Executive Director)*
3. **Ngiam Tong Kwan**  
*(Executive Chairman/Director)*

The Remuneration Committee shall recommend to the Board on the remuneration packages of Executive Directors, Chief Executive Officer and Senior Management of the Company and the Group in all its forms, drawing from outside advice as necessary.

The remuneration packages of non-executive directors should be determined by the Board of Directors as a whole with the director concerned abstaining from deliberations and voting on the decisions in respect of his individual remuneration.

#### (iii) *Nomination Committee*

The Nomination Committee was established on 20 October 2005 with the following members:

1. **Gan Leng Swee**  
*(Chairman) (Independent Non-Executive Director)*
2. **Dato' Hamzah Bin Mohd Salleh**  
*(Non-Independent Non-Executive Director)*
3. **Dato' Kalsom Binti Abdul Rahman**  
*(Independent Non-Executive Director)*

The Nomination Committee shall:

1. Recommend the nomination of a person or persons for all directorships to be filled by the shareholders or the Board;
2. Consider, in making its recommendations, candidates for directorships proposed by the Chief Executive Officer and, within the bounds of practicability, by any other senior executive or any director or shareholder;
3. Recommend to the Board, directors to fill the seats on Board committees;
4. Assess annually the effectiveness of the Board as a whole, the committees of the Board and the contribution of each existing individual director and thereafter, recommend its findings to the Board; and
5. Review annually the required mix of skills and experience and other qualities, including core competencies which non-executive directors should bring to the board and thereafter, recommend its findings to the Board.

## 1. Board of Directors (continued)

### e. Board Committees (continued)

#### (iv) Risk Assessment and Monitoring Committee

The Risk Assessment and Monitoring Committee was established on 20 October 2005 and the members of the Risk Assessment and Monitoring Committee are:

1. **Gan Leng Swee**  
(Chairman) (Independent Non-Executive Director)
2. **Chong Ai Wan**  
(Independent Non-Executive Director)
3. **Ngiam Tee Wee**  
(Chief Executive Officer/Executive Director)

The duties and responsibilities of the Risk Assessment and Monitoring Committee are as follows:

- i. To provide oversight, direction and counsel to the risk management process.
- ii. To establish risk management guidelines.
- iii. To evaluate the structure for the Group risk management, risk management processes and support system.
- iv. To consider the quarterly report on risks, major findings and management responses thereto on material issues, changing environments and required changes in risk management programmes.
- v. To carry out risk assessment on:
  - I. all capital expenditure proposals by the Group of companies exceeding a certain limit;
  - II. any business ventures into new areas of business and any investment outside of Malaysia; and
  - III. any transaction which carries exceptional terms, conditions or obligations including contingent obligations.
- vi. To review and approve action and contingency plans developed to mitigate key risks.
- vii. To advise the Board on the risk related issues and recommend strategies, policies and risk tolerance for Board approval.

### f. Appointment to the Board

Any proposed new appointments to the Board will require deliberation by the full Board guided by a formal recommendation report prepared by the Nomination Committee.

### g. Re-election of Directors

In accordance with the Company's Articles of Association, one-third (1/3) of the Directors shall retire from office provided always that all Directors shall retire from office once at least in each three (3) years, but shall be eligible for re-election. Directors who are appointed by the Board to fill a casual vacancy shall hold office until the next following Annual General Meeting and shall then be eligible for re-election but shall not taken into account in determining the Directors who are to retire by rotation at the meeting.

Directors over seventy (70) years of age are require to submit themselves for re-appointment annually in accordance with Section 129(6) of the Companies Act, 1965.

### h. Directors' Training

All the Directors have attended the Mandatory Accreditation Programme conducted by the Research Institute of Investment Analysts' Malaysia (RIAIAM) and will continue to undergo relevant training programmes from time to time to further enhance their knowledge to enable them to discharge their duties and responsibilities more effectively.

## 2. Directors' Remuneration

The Remuneration Committee recommends to the Board, the remuneration framework and package of the Executive Directors, taking into consideration of the experience, level of responsibilities undertaken and the performance of each Executive Director.

Directors' fees are recommended by the Board for approval by the shareholders of the Company at annual general meetings.

Details of the remuneration of the Directors for the financial year under review are as follows:

	<b>Salaries &amp; bonus RM</b>	<b>Other benefits RM</b>	<b>Fees RM</b>	<b>Total RM</b>
Executive Directors	320,880	–	53,800	374,680
Non-Executive Directors	–	–	36,200	36,200
<b>Total</b>	<b>320,880</b>	<b>–</b>	<b>90,000</b>	<b>410,880</b>

A breakdown of Directors' remuneration for the financial year in successive bands of RM50,000.00 are as follows:

<b>Range of Remuneration (RM)</b>	<b>No. of Directors</b>	
	<b>Executive</b>	<b>Non-Executive</b>
1 – 50,000	–	4
50,001 – 100,000	3	–
100,001 – 150,000	2	–
<b>Total</b>	<b>5</b>	<b>4</b>

## 3. Communication with Shareholders & Investors

The Board values and encourages dialogues with shareholders to facilitate better understanding of the Group's objectives and financial performance.

The Annual General Meeting will be the principal forum for dialogue with individual shareholders, as it provides shareholders the opportunity to ask questions about the resolutions being proposed or about the Company's operations in general, the Board recognizes there is a need to maintain an open and continuous communication outside the general meetings.

Apart from our commitment to ensure that all material information relating to the Group is disclosed in a timely manner through announcements to Bursa Malaysia, the Board plans to establish an investor relations programme as a channel for regular communication with shareholders, stakeholders, investment analysts, fund managers and the media.

## 4. Accountability and Audit

### a. Financial Reporting

In presenting the annual financial statements and quarterly consolidated results, the Board aims to provide a true and fair view of the state of affairs of the Group and of the Company, as well as the results and cash flows of the Group and of the Company. In the preparation of the financial statements, the Group are in compliance of the appropriate accounting policies and approved accounting standards.

In addition, the Audit Committee assists the Board in examining information to be disclosed to the public and relevant regulators to ensure the accuracy and authenticity of such information.

### b. Internal Control

The Board acknowledges its responsibility for maintaining a sound system of internal control. The Board also recognises that reviewing of the Group's systems of internal control is a concerted and continuing process, designed to manage rather than eliminate the risk of failure to achieve business objectives.

A separate statement on Internal Control is provided on page 23.

### c. Relationship with Auditors

The Board has established a formal and transparent arrangement with the Group's auditors in seeking professional advise and ensuring compliance with the approved accounting standard in Malaysia.

## 5. Additional Compliance Information

### a. Utilization of Proceeds

The status of utilisation of proceeds of RM15.70 million raised by the Company from its Initial Public Offering as at the date of this Annual Report is as follows:

	<b>Proposed utilisation RM'000</b>	<b>Actual utilisations RM'000</b>	<b>Balance RM'000</b>
Capital expenditure	4,800	200	4,600
Repayment of bank borrowings	6,900	6,900	–
Working Capital	2,102	1,000	1,102
Estimated listing expenses	1,900	1,754	146
<b>Total</b>	<b>15,702</b>	<b>9,854</b>	<b>5,848</b>

### b. Share Buy-back

There was no share buy-backs during the financial year ended 31 August 2005.

### c. Options, Warrants or Convertible Securities

There were no options, warrants or convertible securities exercised during the financial year ended 31 August 2005.

### d. American Depository Receipt ("ADR")/Global Depository Receipt ("GDR")

The Company did not sponsor any of those programmes.

### e. Sanctions and/or Penalties

There were no sanctions or penalties imposed on the Company and its subsidiaries, directors or management by the relevant regulatory bodies during the financial year under review.

### f. Non-audit Fees

The amount of non-audit fees paid to external auditor by the Group for the current financial year was RM58,800 which was largely for professional services rendered in connection with the Group's listing exercise.

## 5. Additional Compliance Information (continued)

### g. Variation in Results

There is no material variance between the unaudited results, the audited results for the financial year ended 31 August 2005 and the estimated results as set out in the prospectus dated 30 September 2005.

### h. Profit Guarantees

During the financial year, there were no profit guarantees given by the Company or its subsidiaries.

### i. Material Contracts or Loans

Save as disclosed below, there were no material contract has been entered into by the Company and/or its substantial shareholders' interest, either still subsisting at the end of the financial year ended 31 August 2005 or, if not then subsisting, entered into since the end of the previous financial year.

- i. Sale of Shares Agreement dated 31 July 2004 entered into between BSLI and Ngiam Tee Yang in respect of transfer of shares in Shokowsha Technology (M) Sdn Bhd ("Shokowsha") pursuant to which BSLI has agreed to sell 300,000 ordinary share in Shokowsha for a cash consideration of RM300,000 to Ngiam Tee Yang;
- ii. Sale and Purchase Agreement dated 5 August 2004 entered into between Cemerlang Raya (M) Sdn Bhd and BSLI for the purchase of two (2) pieces of freehold industrial land held under Geran No. 29078 Lot 17508 and Geran No. 29087 Lot 17513 Mukim Batu Daerah Gombak, Negeri Selangor measuring approximately 16.1 square metres and 2,910.3 square meters, respectively together with a single storey factory erected on it and known as Lot 17513, Jalan 2, Taman Selayang Baru, 68100 Batu Caves, Selangor for a total cash consideration of RM4,200,000;
- iii. Conditional Sale and Purchase Agreement dated 28 December 2004 entered into between BSL and vendors of BSLI namely Ngiam Tong Kwan, Nyeam Tong Eng @ Ngiam Tong Yang, Teh Eng Hock and Dato' Hamzah Mohd Salleh for the acquisition of 15,000,000 ordinary shares of RM1.00 each in BSLI representing the entire issued and paid-up share capital of BSLI for a purchase consideration of RM34,999,900 to be fully satisfied by the issuance of 69,999,800 BSL Shares at an issue price of RM0.50 per BSL Share;
- iv. Conditional Sale and Purchase Agreement dated 28 December 2004 (and as varied by a letter of agreement dated 28 April 2005) entered into between BSL and vendors of Crestronics namely BSLI and Yukihiro Eguchi for the acquisition of 1,700,000 ordinary shares of RM1.00 each in Crestronics representing the entire issued and paid-up share capital of Crestronics for a purchase consideration of RM5,533,600 to be satisfied by cash consideration of RM4,980,600 and the issuance of 1,106,000 BSL Shares at an issue price of RM0.50 per BSL Share;
- v. Conditional Sale and Purchase Agreement dated 28 December 2004 (and as varied by a letter of agreement dated 28 April 2005) entered into between BSL and vendors of Unique namely BSLI, Teh Yoon Loy, Teh Eng Teck and Teh Eng Seng for the acquisition of 400,000 ordinary shares of RM1.00 each in Unique representing the entire issued and paid-up share capital of Unique for a purchase consideration of RM3,922,546 to be satisfied by cash consideration of RM2,510,546 and the issuance of 2,824,000 BSL Shares at an issue price of RM0.50 per BSL Share;
- vi. Placement Agreement dated 12 September 2005 entered into between BSL and Hwang-DBS whereby BSL has appointed Hwang-DBS to manage the issuance of the Public Issue Shares and act as Placement Agent for the private placement of 6,470,000 Public Issue Shares for a placement fee of up to 2% of the Placement Price of RM0.68 per Placement Share. Further, Hwang-DBS is entitled to charge an administrative fee of 0.25% of the Placement Price of RM0.68 for each Placement Share; and
- vii. Underwriting Agreement dated 19 September 2005 entered into between BSL, Hwang-DBS, Mercury Securities Sdn Bhd and Southern Investment Bank Berhad in relation to the underwriting of 11,010,000 Public Issue Shares for an underwriting commission of 2% of the Issue Price of RM0.68 per Issue share. The Company shall further pay to Hwang-DBS a managing fee of 0.25% on the value of 11,010,000 Public Issue Shares of RM0.68 per Issue Price.

### j. Recurrent Related Party Transactions

All recurrent related party transactions entered into by the Group during the financial year ended 31 August 2005 are disclosed in Note 5 of the financial statements in page 47 of this Annual Report.

### k. Revaluation of landed properties

The Group had, in November year 2004, revalued its landed properties pursuant to the listing exercise of the Company on the Second Board of Bursa Malaysia. The statement regarding the revaluation policy on landed properties is disclosed at Note 3 and 9 of the Notes to the Financial Statements.

## Introduction

The Malaysia Code on Corporate Governance requires listed companies to maintain a sound system of internal controls to safeguard shareholders' investment and the Group assets. Paragraph 15.27 of the Bursa Malaysia Securities Berhad's Listing Requirements requires Directors of listed companies to include a statement on the state of their controls in their Annual Report.

## Board Responsibility

The Board is responsible to maintain a sound system of internal controls and for reviewing its adequacy and integrity. The Board understands that a sound internal control system includes not only financial controls but also operational and compliance controls and risk management. Due to the limitations inherent in an internal control system, the management has implemented an internal control system designed to manage rather than eliminating the risk that may impede the achievement of the Group's business objective. However it was noted that the system will not provide absolute assurance against any material misstatement, fraud or loss.

## System of Internal Control

The key measures implemented in the Group for ensuring and reviewing the effectiveness of the system of internal controls are as follows:

- An organization structure with distinct lines of responsibility, authorization and accountability.
- A management reporting system in place to facilitate timely generation and monitoring of financial information for management review and decision making.
- The continuous accreditation of ISO 9001:2000 Quality Management System.
- Quarterly and annual financial results that are reviewed by the Audit Committee.
- A budgeting process which establishes plans and targets against which performance are monitored on an on-going basis.
- The Group's management team and Executive Directors meet regularly to review the monthly report; monitor the changes in the business development; discuss and resolve key operational and management issues; and review the financial performance against the budget.

To supplement the above measures, the Board has approved the outsourcing of the group's internal audit function to an external professional firm to assist the Audit Committee in reviewing the system of internal control of the Group, and is now in the process of identifying and selecting such a firm. The firm will assess the effectiveness of internal control processes and highlight significant risks impacting the Group.

Overall, the Board recognises that the system of internal control must continuously be improved to cope with the evolving business environment.



The Audit Committee was established on 13 July 2005 and the members of the Audit Committee comprise of:

**Gan Leng Swee**

*Chairman (Independent Non-Executive)*

**Chong Ai Wan**

*Member (Independent Non-Executive)*

**Ngiam Tee Wee**

*Member (Chief Executive Officer)*

The Company was listed on the Second Board of Bursa Malaysia on 15 November 2005. There were no Audit Committee meetings held during the period from the establishment of Audit Committee till the Company's financial year ended 31 August 2005.

## Terms of Reference

The Terms of Reference of the Audit Committee are as follows:

### Composition

1. The Committee shall be appointed by the Board of Directors from among its members. It should fulfil the following requirements:
  - (a) comprise not less than 3 members;
  - (b) the majority shall be independent directors;
  - (c) at least one member:
    - (i) must be a member of the Malaysian Institute of Accountants ("MIA"); or
    - (ii) if he is not a member of MIA, he must have least 3 years' working experience, and he must have passed the examinations specified in Part 1 of the 1st schedule of the Accountants Act, 1967 or he must be a member of one of the associations of accountants specified in Part II of the 1st Schedule of the Accountants Act, 1967; and
  - (d) shall not comprise any alternate director of the Company.
2. In the event of any vacancy resulting in the non-compliance of the above, the Company must fill the vacancy within 3 months.
3. The Board of Directors must review the term of office and performance of the Committee and each of its members at least once every 3 years to determine whether such Committee and members have carried out their duties in accordance with their terms of reference.

## Duties and Responsibilities of the Committee

The Committee shall discharge the following functions:

1. To review the following and report the same to the Board of Directors:
  - (a) with the external auditor, the audit plan, his/her evaluation of the financial system and the system of internal controls, his/her audit report;
  - (b) the assistance given by the employees of the Company to the external auditor;
  - (c) the adequacy of the scope, functions and resources of the internal audit functions and that it has the necessary authority to carry out its work;
  - (d) the internal audit plan, programme, processes, the results of the internal audit activities, processes or investigation undertaken and whether or not appropriate action is taken on the recommendations of the internal audit function;
  - (e) the quarterly results and year-end financial statements, prior to the approval by the Board of Directors;
  - (f) any related party transaction and conflict of interest situation that may arise within the Company or Group;
  - (g) any letter of resignation from the external auditors; and
  - (h) whether there is reason (supported by grounds) to believe that the external auditor is not suitable for re-appointment.
2. To recommend the nomination of a person or persons as external auditors.
3. To report promptly to the Bursa Malaysia where the Committee is of the view that a matter reported by it to the Board of Directors has not been satisfactorily resolved resulting in a breach of the Listing Requirements.
4. To carry out any other function that may be mutually agreed upon by the Committee and the Board of Directors.

## Rights of the Committee

The Committee shall:

1. have authority to investigate any matter within its terms of reference;
2. have the resources which are required to perform its duties;
3. have full and unrestricted access to any information pertaining to the Company and its subsidiary companies;
4. have direct communication channels with the external auditors and person(s) carrying out the internal audit function or activity (if any);
5. be able to obtain independent professional or other advice; and
6. be able to convene meetings with the external auditors, excluding the attendance of the executive board members, whenever deemed necessary.

## Procedure of Committee Meeting

### 1. *Chairman*

The Chairman, who shall be an independent director, shall be elected by the Committee from among their members.

If at any meeting the Chairman is not present within fifteen (15) minutes after the time appointed for holding the meeting, the members present shall choose one of their numbers, to act as Chairman of the meeting.

### 2. *Quorum*

The majority of members who must be the independent directors present shall be a quorum.

### 3. *Attendance*

The head of group finance, the internal auditor and a representative of the external auditor shall normally attend the meeting. However, the Committee may invite any person to be in attendance to assist in its deliberations.

Any one of the Company Secretaries shall act as the secretary of the Committee during the term of his/her appointment.

### 4. *Calling*

Any member may at any time, and the head of group finance and the Secretary shall on the requisition of any of the members or the external auditors summon a meeting.

The meeting may be held at two (2) or more venues within or outside Malaysia using any technology that enable the Audit Committee Members as a whole to participate for the entire duration of the meeting, and that all information and documents for the meeting must be made available to all members prior to or at the meeting. Minutes of the proceedings of such meeting duly signed by the Chairman is sufficient evidence of the proceedings to which it relates.

### 5. *Frequency*

Meetings shall be held at least four (4) times a year.

### 6. *Notice*

Except in the case of an emergency, reasonable notice of every meeting shall be given in writing and the notice of each meeting shall be served to member either personally or by sending it via fax or through the post or by courier or by e-mail to such member to his registered address as appearing in the Register of Directors, as the case may be.

### 7. *Voting*

A resolution put to the vote of the meeting shall be decided on a show of hands.

In the case of an equality of votes, the Chairman shall be entitled to a second or casting vote.

### 8. *Keeping of Minutes*

The minutes shall be signed by the Chairman of the meeting at which the proceedings were held or by the Chairman of the next succeeding meeting and shall be circulated to the Committee.

### 9. *Custody, production and inspection of such minutes*

The minutes shall be kept by the Company at the Registered Office or the principal place of business in Malaysia of the Company, and shall be open for the inspection of any member of the Committee without charge.

## Summary of Activities of the Audit Committee

The Audit Committee did not hold any meeting during the financial period ended 31 August 2005. However, the Audit Committee had held meetings on 20 October 2005 and 23 December 2005 for the following matters relating to the financial year ended 31 August 2005:

- Reviewed the relevant quarterly financial statements before announcement to Bursa Malaysia.
- Reviewed the year-end financial statements together with the External auditors' management letter and management's response.
- Reviewed the reports of the external auditors.

## Internal Audit Function

The Company recognizes that an internal audit function is essential to ensuring the effectiveness of the Group's systems of internal control and is an integral part of the risk management process.

During the financial year ended 31 August 2005, the Group has yet to set up an internal audit department. However, the Company has decided to outsource its internal audit function to an independent professional firm to carry out the review on the adequacy and integrity of the internal control systems of the Group, to assist management in mitigate risk and to assist the Board in performing its oversight responsibility.

# directors' responsibility statement

The Board of Directors is required under Paragraph 15.27(a) of the Bursa Malaysia Listing Requirements to issue a statement explaining its responsibility for preparing the annual audited financial statements.

It is the responsibility of the Board to ensure that the financial statements are prepared in accordance with the provisions of the Companies Act, 1965, and applicable approved accounting standards in Malaysia. In preparing the financial statements on going concern basis, the Board of Directors have selected appropriate accounting policies and applied them consistently and prudently with reasonable judgements and estimates.

The Board of Directors is also responsible for taking such steps as are reasonably available to them to safeguard the assets of the Group and to prevent and detect fraud and other irregularities.

# financial statements

<u>directors' report</u>	30
<u>statement by directors</u>	35
<u>declaration by the officer</u>	35
<u>report of the auditors</u>	36
<u>income statements</u>	37
<u>balance sheets</u>	38
<u>statements of changes in equity</u>	39
<u>cash flow statements</u>	40
<u>notes to the financial statements</u>	42

The directors of BSL CORPORATION BERHAD, have pleasure in submitting their report and the audited financial statements of the Group and of the Company for the financial year ended August 31, 2005.

## Principal Activities

The Company is principally an investment holding company.

The principal activities of the subsidiary companies are disclosed in Note 10 to the Financial Statements.

There have been no significant changes in the nature of the activities of the Company and its subsidiary companies during the financial year.

## Significant Events

In December 2004, the Company submitted an application to the Securities Commission pertaining to the listing of and quotation for its entire issued and paid-up share capital on the Second Board of Bursa Malaysia Securities Berhad which entails the following:

(a) The acquisitions of:

- (i) the entire issued and paid-up share capital of Ban Seng Lee Industries Sdn. Bhd., comprising 15,000,000 ordinary shares of RM1.00 each for a purchase consideration of RM34,999,900, to be fully satisfied by the issuance of 69,999,800 new ordinary shares of the Company at an issue price of RM0.50 per share;
- (ii) the entire issued and paid-up share capital of Unique Forging & Components Sdn. Bhd., comprising 400,000 ordinary shares of RM1.00 each for a purchase consideration of RM3,922,546, to be satisfied by the issuance of 2,824,000 new ordinary shares of the Company at an issue price of RM0.50 per share and cash consideration of RM2,510,546; and
- (iii) the entire issued and paid-up share capital of Crestronics (M) Sdn. Bhd., comprising 1,700,000 ordinary shares of RM1.00 each for a purchase consideration of RM5,533,600, to be satisfied by the issuance of 1,106,000 new ordinary shares of the Company at an issue price of RM0.50 per share and cash consideration of RM4,980,600.

The abovementioned acquisitions were completed on April 28, 2005.

(b) Implementation of a rights issue of 3,696,500 new ordinary shares of RM0.50 each at an issue price of RM0.50 each on a basis of one new ordinary share for every existing twenty shares held after the acquisitions of subsidiary companies as mentioned in (a) above.

(c) Public issue of 20,373,500 new ordinary shares of RM0.50 each at an issue price of RM0.68 per share payable in full on application comprising:

- (i) 7,010,000 new ordinary shares of RM0.50 each available for application by the Malaysian public;
- (ii) 6,470,000 new ordinary shares of RM0.50 each by way of private placement to certain identified investors;
- (iii) 2,893,500 new ordinary shares of RM0.50 each to Bumiputera investors approved by the Ministry of International Trade and Industry; and
- (iv) 4,000,000 new ordinary shares of RM0.50 each available for application by eligible directors, employees and business associates of the Company and its subsidiary companies.

(d) Offer for sale of 6,988,200 new ordinary shares of RM0.50 each at an offer price of RM0.68 per share payable in full on application to Bumiputera investors approved by the Ministry of International Trade and Industry.

The listing has been approved by the relevant regulatory authorities on March 28, 2005 and on November 15, 2005, the entire issued and paid-up share capital of the Company comprising 98,000,000 ordinary shares of RM0.50 each was listed on the Second Board of Bursa Malaysia Securities Berhad ("BMSB").

## Results of Operations

The results of operations of the Group and of the Company for the financial year are as follows:

	<b>The Group RM</b>	<b>The Company RM</b>
Profit before tax	<b>4,999,872</b>	<b>47,767</b>
Income tax expense	<b>(1,610,511)</b>	-
Net profit for the year	<b>3,389,361</b>	<b>47,767</b>

In the opinion of the directors, the results of operations of the Group and of the Company during the financial year have not been substantially affected by any item, transaction or event of a material and unusual nature.

## Dividends

No dividend has been paid or declared by the Company since the end of the previous financial period. The directors also do not recommend any dividend payment in respect of the current financial year.

## Reserves and Provisions

There were no material transfers to or from reserves or provisions during the financial year other than those disclosed in the financial statements.

## Issue of Shares and Debentures

As approved vide a Members' Circular Resolution dated October 15, 2004, the Company effected a share split whereby the authorised share capital of the Company was subdivided into RM100,000 consisting of 200,000 ordinary shares of RM0.50 each.

Also as approved vide the Members' Circular Resolution on the same date, the ordinary and paid-up share capital of the Company was subdivided into RM2 consisting of 4 ordinary shares of RM0.50 each.

On October 18, 2004, the issued and paid-up share capital of the Company was increased from RM2 to RM100, by the issue and allotment of 196 ordinary shares of RM0.50 each at par for cash for the purpose of increasing the working capital of the Company.

As approved vide a Members' Circular Resolution dated April 28, 2005, the authorised share capital of the Company was increased from RM100,000 to RM250,000,000 by the creation of 499,800,000 ordinary shares of RM0.50 each. Also as approved vide the same Members' Circular Resolution, the issued and paid-up share capital of the Company was increased from RM100 to RM36,965,000, by the issue and allotment of 73,929,800 new ordinary shares of RM0.50 each at par for the purposes of acquisition of subsidiary companies as mentioned in Note 27 to the Financial Statements.

The new shares issued rank pari passu in all respects with the then existing shares of the Company.

The Company did not issue any debentures during the financial year.

## Share Options

No options have been granted by the Company to any parties during the financial year to take up unissued shares of the Company.

No shares have been issued during the financial year by virtue of the exercise of any option to take up unissued shares of the Company. As of the end of the financial year, there were no unissued shares of the Company under options.



## Other Financial Information

Before the income statements and the balance sheets of the Group and of the Company were made out, the directors took reasonable steps:

- (a) to ascertain that proper action had been taken in relation to the writing off of bad receivables and the making of allowance for doubtful receivables and have satisfied themselves that there are no known bad receivables to be written off and that adequate allowance for doubtful receivables has been made; and
- (b) to ensure that any current assets which were unlikely to realise their book values in the ordinary course of business have been written down to their estimated realisable values.

At the date of this report, the directors are not aware of any circumstances:

- (a) which would require the writing off of bad receivables or render the amount of allowance for doubtful receivables in the financial statements of the Group and of the Company inadequate to any substantial amount; or
- (b) which would render the values attributed to current assets in the financial statements of the Group and of the Company misleading; or
- (c) which have arisen which render adherence to the existing method of valuation of assets or liabilities of the Group and of the Company misleading or inappropriate; or
- (d) not otherwise dealt with in this report or financial statements which would render any amount stated in the financial statements of the Group and of the Company misleading.

At the date of this report, there does not exist:

- (a) any charge on the assets of the Group and of the Company which has arisen since the end of the financial year and secures the liability of any other person; or
- (b) any contingent liability of the Group and of the Company which has arisen since the end of the financial year.

No contingent or other liability has become enforceable or is likely to become enforceable within the period of twelve months after the end of the financial year which, in the opinion of the directors, will or may substantially affect the ability of the Group and of the Company to meet their obligations as and when they fall due.

In the opinion of the directors, no item, transaction or event of a material and unusual nature has arisen in the interval between the end of the financial year and the date of this report which is likely to affect substantially the results of operations of the Group and of the Company for the succeeding financial year.

## Directors

The following directors served on the Board of the Company since the date of the last report:

Ngiam Tong Kwan	<i>(appointed on 28.4.2005)</i>
Ngiam Tee Wee	<i>(appointed on 28.4.2005)</i>
Ngiam Tee Yang	<i>(appointed on 28.4.2005)</i>
Teh Yoon Loy	<i>(appointed on 28.4.2005)</i>
Yukihiro Eguchi	<i>(appointed on 28.4.2005)</i>
Dato' Hamzah Bin Mohd Salleh	<i>(appointed on 28.4.2005)</i>
Gan Leng Swee	<i>(appointed on 28.4.2005)</i>
Chong Ai Wan	<i>(appointed on 28.4.2005)</i>
Dato' Kalsom Abdul Rahman	<i>(appointed on 28.4.2005)</i>
Yeoh Cheng Lee	<i>(resigned on 28.4.2005)</i>
Wan Heng Chee	<i>(resigned on 28.4.2005)</i>

Messrs. Ngiam Tong Kwan, Ngiam Tee Wee, Ngiam Tee Yang, Teh Yoon Loy, Yukihiro Eguchi, Dato' Hamzah Bin Mohd Salleh, Gan Leng Swee, Chong Ai Wan and Dato' Kalsom Abdul Rahman, who were appointed to the Board since the last Annual General Meeting, shall retire under Article 83 of the Company's Articles of Association in the forthcoming Annual General Meeting and, being eligible, offer themselves for re-election.

## Directors' Interests

The shareholdings in the Company of those who were directors at the end of the financial year, as recorded in the Register of Directors' Shareholdings kept by the Company under Section 134 of the Companies Act, 1965, are as follows:

	Number of ordinary shares of RM0.50 each			Balance at 31.8.2005
	Balance at 1.9.2004 or at date of appointment	Bought	Sold	
<b>Shares in the Company</b>				
<b>Registered in name of directors</b>				
Ngiam Tong Kwan	–	21,069,940	–	<b>21,069,940</b>
Teh Yoon Loy	–	1,882,666	–	<b>1,882,666</b>
Yukihiro Eguchi	–	1,106,000	–	<b>1,106,000</b>
Dato' Hamzah Bin Mohd Salleh	–	20,999,940	–	<b>20,999,940</b>

By virtue of the above directors' interest in the shares of the Company, they are deemed to have an interest in the shares of the subsidiary companies to the extent of the Company's interest.

None of the other directors in office at the end of the financial year held shares or had beneficial interest in the shares of the Company or its related companies during and at the end of the financial year. Under the Company's Articles of Association, the directors are not required to held shares in the Company.

## Directors' Benefits

Since the end of the previous financial year, none of the directors of the Company has received or become entitled to receive any benefit (other than the benefit included in the aggregate amount of emoluments received or due and receivable by directors as disclosed in the financial statements or being the fixed salary of a full-time employee of the Company) by reason of a contract made by the Company or a related corporation with the director or with a firm of which he is a member, or with a company in which he has a substantial financial interest other than any benefit which may be deemed to have arisen by virtue of the transactions as disclosed in Note 5 to the Financial Statements.

During and at the end of the financial year, no arrangement subsisted to which the Company was a party whereby the directors of the Company might acquire benefits by means of the acquisition of shares in, or debentures of, the Company or any other body corporate.

## Holding Company

Subsequent to the financial year, the Company became a subsidiary company of Esteem Role Sdn. Bhd., a company incorporated in Malaysia, following the transfer of 49,980,000 ordinary shares of RM1 each by certain directors of the Company to Esteem Role Sdn. Bhd. The directors of the Company regard Esteem Role Sdn. Bhd. as the ultimate holding company.

## Auditors

The auditors, Messrs. Deloitte KassimChan, have indicated their willingness to continue in office.

Signed on behalf of the Board in accordance with a resolution of the Directors,

**Ngiam Tong Kwan**

**Ngiam Tee Wee**

Petaling Jaya  
December 23, 2005

The directors of **BSL Corporation Berhad**, state that, in their opinion, the accompanying balance sheets and the related statements of income, cash flows and changes in equity are drawn up in accordance with the provisions of the Companies Act, 1965 and the applicable MASB approved accounting standards in Malaysia so as to give a true and fair view of the state of affairs of the Group and of the Company as of August 31, 2005 and of the results and the cash flows of the Group and of the Company for the year ended on that date.

Signed in accordance with a resolution of the Directors,

**Ngiam Tong Kwan**

**Ngiam Tee Wee**

Petaling Jaya  
December 23, 2005

## declaration by the officer primarily responsible for the financial management of the company

I, **Chay Jiun Yee**, the officer primarily responsible for the financial management of **BSL Corporation Berhad**, do solemnly and sincerely declare that the accompanying balance sheets and the related statements of income, cash flows and changes in equity are, in my opinion, correct and I make this solemn declaration conscientiously believing the same to be true, and by virtue of the provisions of the Statutory Declarations Act, 1960.

**Chay Jiun Yee**

Subscribed and solemnly declared by  
the abovenamed Chay Jiun Yee  
at Kuala Lumpur  
this 23rd day of December, 2005.

Before me,

Commissioner for Oaths

# report of the auditors

to the members of bsl corporation berhad

36

BSL CORPORATION BHD • ANNUAL REPORT 2005

We have audited the accompanying balance sheets as of August 31, 2005 and the related statements of income, cash flows and changes in equity for the year then ended. These financial statements are the responsibility of the Company's directors. It is our responsibility to form an independent opinion, based on our audit, on these financial statements and to report our opinion to you, as a body, in accordance with Section 174 of the Companies Act, 1965 and for no other purpose. We do not assume responsibility towards any other person for the content of this report.

We conducted our audit in accordance with approved standards on auditing in Malaysia. These standards require that we plan and perform the audit to obtain reasonable assurance about whether the financial statements are free of material misstatement. An audit includes examining, on a test basis, evidence supporting the amounts and disclosures in the financial statements. An audit also includes assessing the accounting principles used and significant estimates made by the directors, as well as evaluating the overall financial statements presentation. We believe that our audit provides a reasonable basis for our opinion.

In our opinion:

- (a) the financial statements are properly drawn up in accordance with the provisions of the Companies Act, 1965 and the applicable Malaysian Accounting Standards Board approved accounting standards in Malaysia so as to give a true and fair view of:
  - (i) the state of affairs of the Group and of the Company as of August 31, 2005 and of the results and the cash flows of the Group and of the Company for the year ended on that date; and
  - (ii) the matters required by Section 169 of the Act to be dealt with in the financial statements and consolidated financial statements; and
- (b) the accounting and other records and the registers required by the Act to be kept by the Company and by the subsidiary companies have been properly kept in accordance with the provisions of the Act.

We are satisfied that the financial statements of the subsidiary companies that have been consolidated with the financial statements of the Company are in form and content appropriate and proper for the purposes of the preparation of the consolidated financial statements, and we have received satisfactory information and explanations as required by us for these purposes.

Our auditors' reports on the financial statements of the subsidiary companies were not subject to any qualification and did not include any comment made under Section 174 (3) of the Act.

**Deloitte KassimChan**

AF 0080

Chartered Accountants

**Rosita Tan**

1874/9/06(J)

Partner

December 23, 2005

# income statements

for the year ended august 31, 2005

(with comparative figures of the company

for the period april 29, 2004 (date of incorporation) to august 31, 2004)

ANNUAL REPORT 2005 • BSL CORPORATION BHD

37

		<b>The Group</b>	<b>The Company</b>	
		<b>2005</b>	<b>2005</b>	<b>2004</b>
	<b>Note</b>	<b>(12 months)</b>	<b>(12 months)</b>	<b>(4 months)</b>
		<b>RM</b>	<b>RM</b>	<b>RM</b>
Revenue		<b>27,113,829</b>	<b>150,000</b>	–
Other operating income		<b>78,492</b>	–	–
Changes in inventories of work-in-progress and finished goods		<b>692,418</b>	–	–
Raw materials and consumables used		<b>(14,274,518)</b>	–	–
Staff costs	5	<b>(5,379,890)</b>	–	–
Depreciation of property, plant and equipment	9	<b>(1,460,106)</b>	–	–
Other operating expenses		<b>(1,386,217)</b>	<b>(102,233)</b>	(4,310)
Profit/(Loss) from operations	5	<b>5,384,008</b>	<b>47,767</b>	(4,310)
Finance costs	6	<b>(395,811)</b>	–	–
Interest income from short-term deposits		<b>11,675</b>	–	–
Profit/(Loss) before tax		<b>4,999,872</b>	<b>47,767</b>	(4,310)
Income tax expense	7	<b>(1,610,511)</b>	–	–
Net profit/(loss) for the year		<b>3,389,361</b>	<b>47,767</b>	(4,310)
Earnings Per Ordinary Share				
Basic (sen)	8	<b>14</b>		

The accompanying Notes form an integral part of the Financial Statements.

# balance sheets

as of august 31, 2005

38

BSL CORPORATION BHD • ANNUAL REPORT 2005

	Note	The Group 2005 RM	The Company 2005 RM	2004 RM
<b>Assets</b>				
Property, plant and equipment	9	41,457,523	–	–
Investment in subsidiary companies	10	–	44,456,046	–
Quoted investment	11	7,700	–	–
<b>Current Assets</b>				
Inventories	12	9,597,830	–	–
Trade receivables	13	13,127,191	–	–
Other receivables and prepaid expenses	13	2,762,997	738,585	–
Amount owing by subsidiary company	10	–	150,000	–
Short-term deposits with licensed banks	14	432,786	–	–
Cash and bank balances	24	6,356,342	100	2
		<b>32,277,146</b>	<b>888,685</b>	<b>2</b>
<b>Current Liabilities</b>				
Trade payables	15	5,301,788	–	–
Other payables and accrued expenses	15	3,419,158	106,543	2,000
Amount owing to subsidiary company	10	–	8,229,731	–
Amount owing to a director	16	–	–	2,310
Hire-purchase payables – current portion	17	1,811,657	–	–
Bank borrowings	18	5,317,321	–	–
Term loans – current portion	19	2,584,099	–	–
Tax liabilities		716,054	–	–
		<b>19,150,077</b>	<b>8,336,274</b>	<b>4,310</b>
<b>Net Current Assets/(Liabilities)</b>		<b>13,127,069</b>	<b>(7,447,589)</b>	<b>(4,308)</b>
<b>Long-term and Deferred Liabilities</b>				
Hire-purchase payables – non-current portion	17	1,894,857	–	–
Term loans – non-current portion	19	5,321,730	–	–
Deferred tax liabilities	20	3,587,378	–	–
		<b>(10,803,965)</b>	<b>–</b>	<b>–</b>
<b>Net Assets/(Liabilities)</b>		<b>43,788,327</b>	<b>37,008,457</b>	<b>(4,308)</b>
<b>Represented By:</b>				
Issued capital	21	36,965,000	36,965,000	2
Reserves	22	6,823,327	43,457	(4,310)
<b>Shareholders' Equity/(Capital Deficiency)</b>		<b>43,788,327</b>	<b>37,008,457</b>	<b>(4,308)</b>

The accompanying Notes form an integral part of the Financial Statements.

# statements of changes in equity

for the year ended august 31, 2005

(with comparative figures of the company

for the period april 29, 2004 (date of incorporation) to august 31, 2004)

ANNUAL REPORT 2005 • BSL CORPORATION BHD

39

	Note	Issued capital RM	Non- distributable reserve on consolidation RM	Distributable unappropriated profit/ (accumulated loss) RM	Total RM
<b>The Group</b>					
<b>Balance as of September 1, 2004</b>		2	–	(4,310)	(4,308)
Net profit for the year		–	–	3,389,361	3,389,361
Issue of shares	21	36,964,998	–	–	36,964,998
Acquisition of subsidiary companies		–	3,438,276	–	3,438,276
<b>Balance as of August 31, 2005</b>		<b>36,965,000</b>	<b>3,438,276</b>	<b>3,385,051</b>	<b>43,788,327</b>
	Note	Issued capital RM	Accumulated loss RM	Total RM	
<b>The Company</b>					
<b>Balance as of April 29, 2004 (date of incorporation)</b>			2	–	2
Net loss for the period			–	(4,310)	(4,310)
<b>Balance as of September 1, 2004</b>			2	(4,310)	(4,308)
Issue of shares	21	36,964,998	–	–	36,964,998
Net profit for the year			–	47,767	47,767
<b>Balance as of August 31, 2005</b>		<b>36,965,000</b>	<b>43,457</b>	<b>37,008,457</b>	

The accompanying Notes form an integral part of the Financial Statements.



# cash flow statements

for the year ended august 31, 2005

(with comparative figures of the company

for the period april 29, 2004 (date of incorporation) to august 31, 2004)

40

BSL CORPORATION BHD • ANNUAL REPORT 2005

	The Group 2005 (12 months) RM	The Company 2005 (12 months) RM	2004 (4 months) RM
<b>Cash Flows from Operating Activities</b>			
Profit/(Loss) before tax	4,999,872	47,767	(4,310)
Adjustments for:			
Depreciation of property, plant and equipment	1,460,106	–	–
Interest expense	395,811	–	–
Allowance for diminution in value of quoted investment	5,000	–	–
Gain on disposal of property, plant and equipment – net	(61,600)	–	–
Interest income	(11,675)	–	–
Operating Profit/(Loss) before Working Capital Changes	6,787,514	47,767	(4,310)
(Increase)/Decrease in:			
Inventories	(824,127)	–	–
Trade receivables	2,496,780	–	–
Other receivables and prepaid expenses	7,129,877	(738,585)	–
Amount owing by subsidiary company	–	(150,000)	–
Increase/(Decrease) in:			
Trade payables	(2,408,970)	–	–
Other payables and accrued expenses	(333,095)	104,543	2,000
Amount owing to subsidiary companies	–	738,585	–
Amount owing to a director	–	(2,310)	2,310
Cash Generated from Operations	12,847,979	–	–
Income tax paid	(674,102)	–	–
Net Cash from Operating Activities	12,173,877	–	–
<b>Cash Flows from Investing Activities</b>			
Proceeds from disposal of property, plant and equipment	70,000	–	–
Interest received	11,675	–	–
Acquisition of subsidiary companies (Note 10)	(3,111,634)	–	–
Additions to property, plant and equipment (Note)	(304,455)	–	–
Net Cash Used In Investing Activities	(3,334,414)	–	–
<b>Cash Flows from Financing Activities</b>			
Proceeds from issuance of shares	98	98	2
Repayment of bank borrowings	(2,905,170)	–	–
Repayment of hire-purchase obligations	(625,020)	–	–
Interest paid	(395,811)	–	–
Short-term deposits pledged with licensed banks	(93,307)	–	–
Net Cash (Used In)/From Financing Activities	(4,019,210)	98	2
<b>Net Increase in Cash and Cash Equivalents</b>	4,820,253	98	2
<b>Cash and Cash Equivalents at Beginning of Year/Period</b>	2	2	–
<b>Cash and Cash Equivalents at End of Year/Period</b> (Note 24)	4,820,255	100	2

## Note:

During the financial year, the Group acquired property, plant and equipment through the following arrangements:

	<b>The Group 2005 (12 months) RM</b>
Total cost of property, plant and equipment acquired	<b>955,636</b>
Less: Purchase consideration satisfied by:	
Term loans	
Hire-purchase arrangements	<b>(252,000)</b>
	<b>(399,181)</b>
Cash payments	<b>304,455</b>

## 1. General Information

The Company is principally an investment holding company.

The principal activities of the subsidiary companies are as disclosed in Note 10.

There have been no significant changes in the nature of the activities of the Company and its subsidiary companies during the financial year.

The registered office of the Company is located at Level 14, Uptown 1, No. 1 Jalan SS21/58, Damansara Uptown, 47400 Petaling Jaya, Selangor Darul Ehsan.

The principal place of business of the Company is located at Lot 47687, Jalan Bukit Idaman 6, Taman Bukit Idaman, 68100 Batu Caves, Selangor Darul Ehsan.

The total number of employees in the Group and the Company as of August 31, 2005 was 924 and Nil (2004: the Company, Nil) respectively.

## 2. Basis of Preparation of the Financial Statements

The financial statements of the Group and of the Company have been approved by the Board of Directors for issuance on December 23, 2005.

The financial statements of the Group and of the Company have been prepared in accordance with the provisions of the Companies Act, 1965 and the applicable Malaysian Accounting Standards Board ("MASB") approved accounting standards in Malaysia.

## 3. Significant Accounting Policies

### Basis of Accounting

The financial statements of the Group and of the Company have been prepared under the historical cost convention modified to include the revaluation of freehold and leasehold land and buildings.

### Basis of Consolidation

The consolidated financial statements include the audited financial statements of the Company and of the subsidiary companies controlled by the Company made up to the end of the financial year.

Subsidiary companies are consolidated using the acquisition method of accounting. On acquisition, the assets and liabilities of the relevant subsidiary companies are measured at their fair values at the date of acquisition. The interest of minority shareholders is stated at the minority's proportion of the fair value of the assets and liabilities recognised.

The results of subsidiary companies acquired or disposed of during the financial year are included in the consolidated financial statements from the effective date of acquisition or up to the effective date of disposal.

All significant intercompany transactions and balances are eliminated on consolidation.

### Reserve on Consolidation

Reserve arising on consolidation represents the excess of the fair values attributable to the related net assets of the subsidiary companies at the date of acquisition over the cost of the Company's investment. Reserve on consolidation is transferred to the income statements upon the disposal of the related investment.

### Revenue

Revenue of the Group represents gross invoiced value of goods sold, net of sales tax, discounts and returns whereas revenue of the Company represents dividend income from subsidiary companies. Sales of goods are recognised upon delivery of products and when risks and rewards of ownership have passed and dividend income is recognised when the shareholders' rights to receive payment is established.

### 3. Significant Accounting Policies (continued)

#### Employee Benefits

##### (i) Short Term Employee Benefits

Wages, salaries, bonuses and non-monetary benefits are accrued for in the period in which the associated services are rendered by the employees of the Group.

##### (ii) Defined Contribution Plan

The Group makes contributions to the Employees' Provident Fund ("EPF") and the contributions to the EPF are charged to the income statements in the period in which they relate. Once the obligations have been paid, the Group has no further payment obligations. The Group's contributions to EPF are included under staff costs as mentioned in Note 5.

#### Foreign Currency Conversion

Transactions in foreign currencies are converted into Ringgit Malaysia at the exchange rates prevailing at the transaction dates or where settlement has not yet been made at the end of the financial year, at the approximate exchange rates prevailing at that date. All foreign exchange gains or losses are reflected in the income statements.

The exchange rates of foreign currencies against Ringgit Malaysia ruling at balance sheet date are as follows:

	2005 RM	2004 RM
<b>Currencies</b>		
1 United States Dollar	<b>3.7698</b>	3.8000
1 Singapore Dollar	<b>2.2395</b>	2.2000

#### Income Tax

The tax effects of transactions are recognised, using the "balance sheet" method and all taxable temporary differences are recognised. Where deductible temporary differences, unused tax losses and unused tax credits would give rise to net deferred tax assets, the tax effects are recognised to the extent that it is probable that taxable profits will be available against which the deductible temporary differences can be utilised.

#### Property, Plant and Equipment and Depreciation

Property, plant and equipment are stated at cost/valuation less accumulated depreciation and impairment losses, if any.

Freehold and leasehold land and buildings are stated at valuation and are revalued at regular intervals of at least once in every three to five years by the directors based on the valuation reports of independent professional valuers using the "open market value on existing use" basis with additional valuation in the intervening years where market conditions indicate that the carrying values of the revalued assets differ materially from the market value.

An increase in the carrying amount arising from revaluation of property, plant and equipment is credited to the revaluation reserve account as revaluation surplus. Any deficit arising from revaluation is charged against the revaluation reserve account to the extent of a previous surplus held in the revaluation reserve account for the same asset. In all other cases, a decrease in carrying amount is charged to income statements. An increase in revaluation directly related to a previous decrease in carrying amount for that same asset that was recognised as an expense, is credited to income statements to the extent that it offsets the previously recorded decrease.

Gain or loss arising from the disposal of an asset is determined as the difference between the estimated net disposal proceeds and the carrying amount of the asset, and is recognised in the income statements. On disposal of revalued assets, the amounts in revaluation reserve account relating to the assets disposed are transferred to unappropriated profit account.

### 3. Significant Accounting Policies (continued)

#### Property, Plant and Equipment and Depreciation (continued)

Property, plant and equipment, except for freehold land which is not depreciated, are depreciated on the straight-line method to their estimated residual values at the following annual rates based on the estimated useful lives of the various assets:

Leasehold land	90 – 99 years
Buildings	2%
Plant and machinery	10% – 12%
Office equipment, furniture, fittings, renovation, factory upgrade and factory equipment	8% – 16%
Motor vehicles	10% – 20%

#### Assets Acquired under Hire-Purchase Arrangements

Property, plant and equipment acquired under hire-purchase arrangements are capitalised in the financial statements and the corresponding obligations are recorded as liabilities. Finance charges are allocated to the income statements to give a constant periodic rate of interest on the remaining hire-purchase liabilities.

#### Investment in Subsidiary Companies

Investment in subsidiary companies, which is eliminated on consolidation, is stated at cost less impairment losses in the Company's financial statements.

#### Quoted Investment

Quoted investment represents investment in quoted shares of local corporations and is stated at cost less impairment losses.

#### Impairment of Assets

The carrying amounts of property, plant and equipment, investment in subsidiary companies and other investment are reviewed at each balance sheet date to determine whether there is any indication of impairment. If any such indication exists, the asset's recoverable amount is estimated. An impairment loss is recognised whenever the carrying amount of an asset or its cash-generating unit exceeds its recoverable amount. All impairment losses are recognised in the income statements.

An impairment loss is only reversed to the extent that the asset's carrying amount does not exceed the carrying amount that would have been determined, net of depreciation or amortisation, if no impairment loss had been recognised. All reversals are recognised in the income statements.

#### Inventories

Inventories are valued at the lower of cost (determined principally on the 'first-in, first-out' basis) and net realisable value. The cost of raw materials comprises the original purchase price plus the costs incurred in bringing these inventories to their present location and condition. The cost of finished goods and work-in-progress include the costs of raw materials, direct labour and a proportion of the production overheads.

Net realisable value represents the estimated selling price in the ordinary course of business less selling and distribution costs and all other estimated costs to completion. Net realisable value is arrived at after considering the allowance for obsolete and slow-moving inventories.

#### Receivables

Trade and other receivables are stated at nominal value as reduced by the appropriate allowances for estimated irrecoverable amounts. Allowance for doubtful receivables is made based on estimates of possible losses which may arise from non-collection of certain receivable accounts.

### 3. Significant Accounting Policies (continued)

#### Provisions

Provisions are made when the Group and the Company have a present legal or constructive obligation as a result of past events, when it is probable that an outflow of resources will be required to settle the obligation, and when a reliable estimate of the amount can be made.

#### Financial Assets

The Group's principal financial assets are trade and other receivables and cash and cash equivalents. The principal financial assets of the Company also include amount owing by subsidiary company.

#### Financial Liabilities

Equity instruments and financial liabilities are classified as either equity or liabilities in accordance with the substance of the contractual arrangement.

Significant financial liabilities of the Group include trade and other payables, hire-purchase payables and bank borrowings. Financial liabilities of the Company also include amount owing to subsidiary company.

Bank borrowings are recorded at the proceeds received net of direct issue costs and finance costs are accounted for on an accrual basis.

#### Cash Flow Statements

The Group and the Company adopt the indirect method in the preparation of the cash flow statements.

Cash equivalents are short-term, highly liquid investments with maturities of three months or less from the date of acquisition and are readily convertible to cash without significant risks of changes in value.

### 4. Segment Reporting

#### Business Segments

For management purposes, the Group is organised into the following segments:

- (i) Stamping and manufacturing of precision metal parts and fabrication of tools and dies.
- (ii) Printed circuit board ("PCB") assembly and assembly of all types of electronics and electrical components, devices and systems.
- (iii) Fabrication and forging of base metal components.

Inter-segment sales are charged at cost plus a percentage of profit mark-up.

## 4. Segment Reporting (continued)

	Precision stamping and tooling RM	PCB and module assembly RM	Fabrication and forging RM	Eliminations RM	Consolidated RM
<b>The Group – 2005</b>					
<b>Revenue</b>					
External sales	18,131,653	5,781,815	3,200,361	–	27,113,829
Inter-segment sales	–	–	43,486	(43,486)	–
Total revenue	18,131,653	5,781,815	3,243,847	(43,486)	27,113,829
<b>Results</b>					
Segment results	4,181,019	673,504	631,718	–	5,486,241
Unallocated corporate expenses					(102,233)
Profit from operations					5,384,008
Finance costs					(395,811)
Interest income from short-term deposits					11,675
Profit before tax					4,999,872
Income tax expense					(1,610,511)
Net profit for the year					3,389,361
<b>Other Information</b>					
Capital additions	329,765	460,839	165,032	–	955,636
Depreciation of property, plant and equipment	632,763	573,581	253,762	–	1,460,106
<b>Consolidated Balance Sheets</b>					
<b>Assets</b>					
Segment assets	44,961,084	17,953,545	10,089,155	–	73,003,784
Unallocated corporate assets					738,585
Consolidated total assets					73,742,369
<b>Liabilities</b>					
Segment liabilities	14,962,734	6,973,817	3,714,059	–	25,650,610
Unallocated corporate liabilities					4,303,432
Consolidated total liabilities					29,954,042

### Geographical Segments

The Group's operations are located mainly in Malaysia. Therefore, information on geographical segments is not presented.

## 5. Profit/(Loss) from Operations

Profit/(Loss) from operations is arrived at:

	The Group 2005 (12 months) RM	The Company 2005 (12 months) RM	2004 (4 months) RM
<b>After charging:</b>			
Directors' remuneration			
– Other emoluments	320,880	–	–
– Fees	90,000	90,000	–
Rental of premises payable to:			
Related parties (Note)	74,000	–	–
Third parties	24,520	–	–
Rental of machinery	54,790	–	–
Auditors' remuneration	25,000	10,000	1,000
Allowance for diminution in value of quoted investment	5,000	–	–
Realised loss on foreign exchange	2,516	–	–
	<hr/>		
<b>And crediting:</b>			
Gain on disposal of property, plant and equipment – net	61,600	–	–
	<hr/>		

Staff costs include salaries, contributions to EPF, bonuses and all other staff related expenses. During the financial year, included in staff costs are contributions to EPF made by the Group amounting to RM370,474.

*Note:*

*The rental of premises is paid to related parties, Teh & Co. Sdn. Bhd. and Teh Chooi Choon Enterprise Sdn. Bhd., companies in which a director of the Company is also a director.*

The directors of the Company are of the opinion that the above transactions have been entered into in the normal course of business and have been established under terms that are no less favourable than those arranged with independent third parties.

## 6. Finance Costs

	The Group 2005 (12 months) RM
Interest on:	
Term loans	155,448
Trust receipts and bankers' acceptances	99,219
Hire-purchase	88,689
Bank overdrafts	52,455
	<hr/>
	395,811
	<hr/>



## 7. Income Tax Expense

	<b>The Group</b> <b>2005</b> <b>(12 months)</b> <b>RM</b>	<b>The Company</b> <b>2005</b> <b>(12 months)</b> <b>RM</b>	<b>2004</b> <b>(4 months)</b> <b>RM</b>
Estimated current tax:			
Income tax	959,370	–	–
Deferred tax (Note 20)	307,195	–	–
	<b>1,266,565</b>	–	–
Underprovision in prior years:			
Income tax	45,943	–	–
Deferred tax (Note 20)	298,003	–	–
	<b>343,946</b>	–	–
	<b>1,610,511</b>	–	–

A reconciliation of income tax expense applicable to profit/(loss) before tax at the applicable statutory income tax rates to income tax expense at the effective income tax rates of the Group and of the Company is as follows:

	<b>The Group</b> <b>2005</b> <b>(12 months)</b> <b>RM</b>	<b>The Company</b> <b>2005</b> <b>(12 months)</b> <b>RM</b>	<b>2004</b> <b>(4 months)</b> <b>RM</b>
Profit/(Loss) before tax	4,999,872	47,767	(4,310)
Tax at the statutory tax rates of:			
20% on first RM500,000 of chargeable income	291,747	–	–
28% on balance of chargeable income	992,919	13,375	(1,207)
Tax effects of:			
Expenses which are not deductible in determining taxable profit	359,799	28,625	1,207
Reinvestment allowance claimed	(377,900)	–	–
Tax exempt dividend received from subsidiary company	–	(42,000)	–
	<b>1,266,565</b>	–	–

Under Schedule 7A of the Income Tax Act, 1967, the Group is allowed to claim reinvestment allowances and as of August 31, 2005, the Group has unutilised reinvestment allowances of approximately RM435,000. The unutilised reinvestment allowances is subject to the approval by the tax authorities and available for offset against future business income.

As of August 31, 2005, the tax exempt income of the Group is as follows:

	<b>Note</b>	<b>The Group</b> <b>2005</b> <b>RM</b>
Reinvestment allowances claimed and utilised	(i)	13,945,000
Tax exempt account	(ii)	3,515,000
		<b>17,460,000</b>

- (i) Arising from reinvestment allowances claimed and utilised under Schedule 7A of the Income Tax Act, 1967.
- (ii) Arising from chargeable income on which tax was waived in 1999 in accordance with the Income Tax (Amendment) Act, 1999.

The above tax exempt accounts, which are subject to approval by the tax authorities, are available for the distribution of tax exempt dividends to the shareholders without incurring any further tax liabilities.

## 8. Earnings Per Ordinary Share

	<b>The Group 2005 (12 months) RM</b>
Net profit attributable to shareholders	<b>3,389,361</b>
Weighted average number of ordinary share in issue	<b>24,643,400</b>
Earnings per ordinary share – Basic (sen)	<b>14</b>

9. Property, Plant and Equipment

2005	Cost					Comprising		
	At beginning of year RM	Additions RM	Acquisition of subsidiary companies RM	Disposals RM	At end of year RM	At cost RM	At valuation RM	Total RM
<b>The Group</b>								
Freehold land	-	-	5,589,154	-	5,589,154	2,775,538	2,813,616	5,589,154
Leasehold land	-	-	6,803,200	-	6,803,200	-	6,803,200	6,803,200
Buildings	-	-	8,488,029	-	8,488,029	1,744,845	6,743,184	8,488,029
Plant and machinery	-	672,712	38,113,997	(40,000)	38,746,709	38,746,709	-	38,746,709
Office equipment, furniture, fittings, renovation, factory upgrade and factory equipment	-	134,698	3,263,140	-	3,397,838	3,397,838	-	3,397,838
Motor vehicles	-	148,226	2,227,967	-	2,376,193	2,376,193	-	2,376,193
	-	955,636	64,485,487	(40,000)	65,401,123	49,041,123	16,360,000	65,401,123
	Accumulated Depreciation					Comprising		Net book value
	At beginning of year RM	Additions RM	Acquisition of subsidiary companies RM	Disposals RM	At end of year RM	At cost RM	At valuation RM	RM
<b>The Group</b>								
Freehold land	-	-	-	-	-	-	-	5,589,154
Leasehold land	-	24,187	48,374	-	72,561	-	72,561	6,730,639
Buildings	-	29,106	140,655	-	169,761	34,897	134,864	8,318,268
Plant and machinery	-	1,175,755	19,342,945	(31,600)	20,487,100	20,487,100	-	18,259,609
Office equipment, furniture, fittings, renovation, factory upgrade and factory equipment	-	90,380	1,709,999	-	1,800,379	1,800,379	-	1,597,459
Motor vehicles	-	140,678	1,273,121	-	1,413,799	1,413,799	-	962,394
	-	1,460,106	22,515,094	(31,600)	23,943,600	23,736,175	207,425	41,457,523

## 9. Property, Plant and Equipment (continued)

The details of the valuation of the Group's freehold and leasehold land and buildings are as follows:

Details of properties	Year of valuation	Details of valuers	The Group 2005 Revalued amount RM
Freehold land and buildings	2004	Long Tian Chek, B.Sc., MRICS, MIS (M) Registered Valuer of Henry Butcher, Lim & Long (Selangor) Sdn. Bhd. and Siew Weng Hong, Registered Valuer of Henry Butcher Malaysia (NS) Sdn. Bhd.	5,660,000
Leasehold land and buildings	2004	Long Tian Chek, B.Sc., MRICS, MIS (M) Registered Valuer of Henry Butcher, Lim & Long (Selangor) Sdn. Bhd. and Siew Weng Hong, Registered Valuer of Henry Butcher Malaysia (NS) Sdn. Bhd.	10,700,000
			<b>16,360,000</b>

The above valuations were undertaken by registered valuers and independent firms of professional valuers, using the "open market value on existing use" basis.

The historical costs and carrying values of the said revalued properties are as follows:

	The Group 2005 RM
Cost:	
Leasehold land and buildings	10,321,736
Freehold land and buildings	4,892,335
	15,214,071
Accumulated depreciation of leasehold land and buildings	(1,216,516)
Net book value	<b>13,997,555</b>

As of August 31, 2005, the unexpired lease period of the Group's leasehold land ranges from 85 to 91 years.

Included in property, plant and equipment of the Group are the following assets acquired under hire-purchase arrangements:

	The Group 2005 RM
Net Book Value:	
Plant and machinery	4,592,321
Motor vehicles	378,493
	<b>4,970,814</b>

## 9. Property, Plant and Equipment (continued)

Included in property, plant and equipment of the Group are the following fully depreciated assets which are still in use:

	<b>The Group 2005 RM</b>
Cost:	
Plant and machinery	6,343,667
Office equipment, furniture, fittings, renovation, factory upgrade and factory equipment	824,363
Motor vehicles	271,039
	<b>7,439,069</b>

As of August 31, 2005, the following property, plant and equipment are pledged to licensed banks and financial institutions as security for credit facilities granted to the Group:

	<b>The Group 2005 RM</b>
Net Book Value:	
Buildings	8,122,268
Leasehold land	6,730,639
Freehold land	5,589,154
Plant and machinery	4,871,923
	<b>25,313,984</b>

## 10. Investment in Subsidiary Companies

	<b>The Company</b>	
	2005	2004
	RM	RM
Unquoted shares in Malaysia – at cost	44,546,046	–

The details of the subsidiary companies, which are incorporated in Malaysia, are as follows:

<b>Name of subsidiary companies</b>	<b>Equity interest held (%)</b>		<b>Principal activities</b>
	<b>2005</b>	<b>2004</b>	
<b>Direct</b>			
Ban Seng Lee Industries Sdn. Bhd.	100	–	Stamping and manufacturing of precision metal parts and fabrication of tools and dies.
Crestronics (M) Sdn. Bhd.	100	–	Printed circuit board assembly and assembly of all types of electronic and electrical components, devices and system.
Unique Forging & Components Sdn. Bhd.	100	–	Fabrication and forging of base metal components.
<b>Indirect – held through</b>			
<b>Ban Seng Lee Industries Sdn. Bhd.</b>			
Kotamech Engineering Sdn. Bhd.	100	–	Engineering works. Ceased operations since 2004.

During the financial year, the Company acquired 100% of the equity interest in the abovementioned subsidiary companies pursuant to its listing on the Second Board of Bursa Malaysia Securities Berhad (“BMSB”) (Note 27).

## 10. Investment in Subsidiary Companies (continued)

The effect of the abovementioned acquisitions on the financial results of the Group for the current financial year are as follows:

	<b>2005 RM</b>
Revenue	27,113,829
Other operating income	78,492
Changes in inventories of work-in-progress and finished goods	692,418
Raw materials and consumables used	(14,274,518)
Staff costs	(5,379,890)
Depreciation of property, plant and equipment	(1,460,106)
Other operating expenses	(1,283,984)
Profit from operations	5,486,241
Finance costs	(395,811)
Interest income from short-term deposits	11,675
Profit before tax	5,102,105
Income tax expense	(1,610,511)
Income in Group profit attributable to shareholders	<u>3,491,594</u>

The effect of the abovementioned acquisitions on the financial position of the Group as of date of acquisition are as follows:

	<b>2005 RM</b>
Property, plant and equipment	41,970,393
Quoted investment	12,700
Inventories	8,773,703
Trade receivables	15,623,971
Other receivables and prepaid expenses	1,553,665
Tax recoverable	467,530
Amount owing to holding company	7,491,146
Cash and bank balances	6,521,778
Trade payables	(7,710,758)
Other payables and accrued expenses	(3,752,253)
Hire-purchase payables	(3,932,353)
Term loans	(8,627,903)
Bank overdrafts	(2,055,768)
Bank borrowings	(5,372,851)
Deferred tax liabilities	(2,982,180)
Reserve on consolidation	(3,438,276)
Total	44,542,544
Less: Purchase consideration satisfied by issue of shares	(36,964,900)
Less: Cash and cash equivalents	(4,466,010)
Cash flow on acquisition, net of cash and cash equivalents acquired	<u>3,111,634</u>

The amount owing by subsidiary company arose mainly from dividend receivable which is unsecured, interest free and has no fixed terms of repayments.

The amount owing to subsidiary company arose mainly from consideration payable on the acquisition of subsidiary companies and payments made on behalf which is unsecured, interest free and has no fixed terms of repayment.

## 11. Quoted Investment

	<b>The Group 2005 RM</b>
Quoted investment in shares of local corporations	12,700
Less: Allowance for diminution in value	(5,000)
Net	<u>7,700</u>
Market value	<u>7,700</u>

## 12. Inventories

	<b>The Group 2005 RM</b>
At cost:	
Raw materials	4,131,253
Work-in-progress	3,321,154
Finished goods	2,145,423
	<u>9,597,830</u>

## 13. Trade Receivables, Other Receivables and Prepaid Expenses

### (i) Trade receivables

Trade receivables comprise amounts receivable for sales of goods. The credit period granted by the Group on sale of goods range from 60 to 90 days.

	<b>The Group 2005 RM</b>
Trade receivables	13,593,092
Less: Allowance for doubtful receivables	(465,901)
Net	<u>13,127,191</u>

The foreign currencies profile of trade receivables is as follows:

	<b>The Group 2005 RM</b>
Ringgit Malaysia	13,492,663
United States Dollar	100,429
	<u>13,593,092</u>

## 13. Trade Receivables, Other Receivables and Prepaid Expenses (continued)

### (ii) Other receivables and prepaid expenses

	<b>The Group</b>	<b>The Company</b>	
	<b>2005</b>	<b>2005</b>	<b>2004</b>
	<b>RM</b>	<b>RM</b>	<b>RM</b>
Prepaid expenses	1,063,751	738,585	–
Tax recoverable	852,373	–	–
Other receivables	546,616	–	–
Refundable deposits	300,257	–	–
	<b>2,762,997</b>	<b>738,585</b>	<b>–</b>

## 14. Short-Term Deposits with Licensed Banks

Included in the short-term deposits of the Group are RM93,307, pledged to a licensed bank as collateral for term loans, bank overdrafts and other credit facilities granted to a subsidiary company as mentioned in Notes 18 and 19.

## 15. Trade Payables, Other Payables and Accrued Expenses

### (i) Trade payables

Trade payables comprise amounts outstanding for trade purchases and ongoing costs. The credit period granted to the Group on purchases of goods ranges from 60 to 90 days.

The foreign currencies profile of trade payables is as follows:

	<b>The Group</b>
	<b>2005</b>
	<b>RM</b>
Ringgit Malaysia	5,216,673
United States Dollar	81,428
Singapore Dollar	3,687
	<b>5,301,788</b>

### (ii) Other payables and accrued expenses

	<b>The Group</b>	<b>The Company</b>	
	<b>2005</b>	<b>2005</b>	<b>2004</b>
	<b>RM</b>	<b>RM</b>	<b>RM</b>
Other payables	2,984,784	91,843	–
Accrued expenses	434,374	14,700	2,000
	<b>3,419,158</b>	<b>106,543</b>	<b>2,000</b>

## 16. Amount Owing to a Director

In 2004, the amount owing to a director arose mainly from expenses paid on behalf which was unsecured, interest free and had no fixed terms of repayment.



## 17. Hire-Purchase Payables

	<b>The Group 2005 RM</b>
Total outstanding	3,989,927
Less: Interest-in-suspense	(283,413)
Principal outstanding	<u>3,706,514</u>
Less: Portion due within the next 12 months (shown under current liabilities)	<u>(1,811,657)</u>
Non-current portion	<u>1,894,857</u>

The non-current portion is repayable as follows:

	<b>The Group 2005 RM</b>
Financial year ending August 31:	
2007	1,644,483
2008	250,374
	<u>1,894,857</u>

The term of the hire-purchase payables is 2 to 3 years and interest rates implicit in the hire-purchase arrangements range from 2.55% to 8.60% per annum. The interest rates are fixed at the inception of the hire-purchase arrangement.

## 18. Bank Borrowings

	<b>The Group 2005 RM</b>
Bankers' acceptances	3,151,054
Bank overdrafts (Note 24)	1,875,566
Bills payable	290,701
	<u>5,317,321</u>

The Group has bank overdrafts and other credit facilities amounting to RM21,000,000 which bear interest at rates ranging from 7.00% to 7.75% per annum. The overdrafts and other credit facilities are secured by joint and several guarantees by certain directors of the Company and fixed and floating charge over certain property, plant and equipment of the subsidiary companies (Note 9) and short-term deposits of a subsidiary company (Note 14).

## 19. Term Loans

	<b>The Group 2005 RM</b>
Total outstanding	7,905,829
Less: Portion due within the next 12 months (shown under current liabilities)	(2,584,099)
Non-current portion	<u>5,321,730</u>

The non-current portion of the term loans is repayable as follows:

	<b>The Group 2005 RM</b>
Financial year ending August 31:	
2007	2,117,743
2008	864,952
2009 and thereafter	2,339,035
	<u>5,321,730</u>

The term loans of the Group are secured by joint and several guarantees by certain directors of the Company and fixed and floating charge over certain property, plant and equipment of the subsidiary companies (Note 9) and short-term deposits of a subsidiary company (Note 14). The term loans of the Group bear interest at rates ranging from 3.90% to 8.50% per annum.

## 20. Deferred Tax Liabilities

	<b>The Group 2005 RM</b>
At beginning of year	–
Arising from the acquisition of subsidiary companies	2,982,180
Transfer from income statements (Note 7)	605,198
At end of year	<u>3,587,378</u>

	<b>Deferred Tax Liabilities The Group 2005 RM</b>
The deferred tax liabilities are in respect of the tax effects of:	
Temporary differences in respect of property, plant and equipment	3,269,762
Revaluation of freehold and leasehold land and buildings	313,616
Others	4,000
	<u>3,587,378</u>

## 21. Share Capital

	The Group and the Company	
	2005 RM	2004 RM
<b>Authorised:</b>		
Ordinary shares of RM1 each:		
At beginning of year/At date of incorporation	100,000	100,000
Created during the year/period	249,900,000	–
At end of year/period	250,000,000	100,000
<b>Issued and Fully Paid:</b>		
Ordinary shares of RM1 each:		
At beginning of year/At date of incorporation	2	2
Issued during the year/period	36,964,998	–
At end of year/period	36,965,000	2

As approved vide a Members' Circular Resolution dated October 15, 2004, the Company effected a share split whereby the authorised share capital of the Company was subdivided into RM100,000 consisting of 200,000 ordinary shares of RM0.50 each.

Also as approved vide the Members' Circular Resolution on the same date, the ordinary and paid-up share capital of the Company was subdivided into RM2 consisting of 4 ordinary shares of RM0.50 each.

On October 18, 2004, the issued and paid-up share capital of the Company was increased from RM2 to RM100, by the issue and allotment of 196 ordinary shares of RM0.50 each at par for cash for the purpose of increasing the working capital of the Company.

As approved vide a Members' Circular Resolution dated April 28, 2005, the authorised share capital of the Company was increased from RM100,000 to RM250,000,000 by the creation of 499,800,000 ordinary shares of RM0.50 each. Also as approved vide the same Members' Circular Resolution, the issued and paid-up share capital of the Company was increased from RM100 to RM36,965,000, by the issue and allotment of 73,929,800 new ordinary shares of RM0.50 each at par for the purposes of acquisition of subsidiary companies as mentioned in Note 27.

Subsequent to the financial year:

- (i) As approved vide a Members' Circular Resolution dated September 15, 2005, a rights issue of 3,696,500 new ordinary shares of RM0.50 each at an issue price of RM0.50 each was implemented on a basis of one new ordinary share for every existing twenty shares held.
- (ii) The Company undertook a public issue of 20,373,500 new ordinary shares of RM0.50 each at an issue price of RM0.68 per share to various investors pursuant to its listing on the Second Board of BMSB.

## 22. Reserves

	Note	The Group 2005 RM	The Company 2005 RM	2004 RM
Reserve on consolidation	(i)	3,438,276	–	–
Unappropriated profit/(Accumulated loss)	(ii)	3,385,051	43,457	(4,310)
		<b>6,823,327</b>	<b>43,457</b>	<b>(4,310)</b>

- (i) Reserve on consolidation represents the excess of the fair value attributable to the related net assets of subsidiary companies at date of acquisition over the Company's cost of investment.

The movements in reserve on consolidation are as follows:

	The Group 2005 (12 months) RM
At beginning of year	–
Acquisition of subsidiary companies	3,438,276
At end of year	<b>3,438,276</b>

- (ii) Based on the estimated tax credits and the prevailing tax rate applicable to dividends, the Company is able to distribute its entire unappropriated profits as of August 31, 2005 by way of cash dividend without additional tax liability being incurred.

## 23. Holding Company

Subsequent to the financial year, the Company became a subsidiary company of Esteem Role Sdn. Bhd., a company incorporated in Malaysia, following the transfer of 49,980,000 ordinary shares of RM1 each by certain directors of the Company to Esteem Role Sdn. Bhd. The directors of the Company regard Esteem Role Sdn. Bhd. as the ultimate holding company.

## 24. Cash and Cash Equivalents

	The Group 2005 RM	The Company 2005 RM	2004 RM
Cash and bank balances	6,356,342	100	2
Short-term deposits with licensed banks	432,786	–	–
Bank overdrafts (Note 18)	(1,875,566)	–	–
	<b>4,913,562</b>	<b>100</b>	<b>2</b>
Less: Short-term deposits pledged (Note 14)	(93,307)	–	–
	<b>4,820,255</b>	<b>100</b>	<b>2</b>

The said short-term deposits of the Group bear interest at rates ranging from 2.5% to 3.0% per annum and have an average maturity period of 30 days.

The foreign currencies profile of cash and bank balances is as follows:

	The Group 2005 RM	The Company 2005 RM	2004 RM
Ringgit Malaysia	6,322,562	100	2
United States Dollar	33,780	–	–
	<b>6,356,342</b>	<b>100</b>	<b>2</b>

## 25. Financial Instruments

### Financial risk management objectives and policies

The operations of the Group are subject to a variety of financial risks, including foreign currency risk, interest rate risk, credit risk, liquidity risk and cash flow risk. The Group has taken measures to minimise its exposure to risk and/or costs associated with the financing, investing and operating activities.

### Foreign currency risk

The Group undertakes minimal trade transactions which are denominated in foreign currencies. As a result, the Group's exposure to foreign currency risk is limited.

### Interest rate risk

The Group is exposed to interest rate risk through the impact of rate changes on short-term deposits, hire-purchase payables and bank borrowings. The interest rates of short-term deposits, hire-purchase payables, bank borrowings and term loans are disclosed in Notes 24, 17, 18 and 19 respectively.

### Credit risk

The Group is mainly exposed to credit risk from trade receivables.

The Group's exposure to credit risk in relation to its trade receivables, should all its customers fail to perform their obligations as of August 31, 2005, is the carrying amount of these receivables as disclosed in the balance sheets.

### Liquidity risk

The Group practises prudent liquidity risk management to minimise the mismatch of financial assets and liabilities and to maintain sufficient credit facilities as disclosed in Note 18 for contingent funding requirement of working capital.

### Cash flow risk

The Group reviews its cash flow position regularly to manage its exposure to fluctuations in future cash flows associated with its monetary financial instruments.

### Fair values of financial assets and liabilities

The carrying amounts of the Group's financial assets and liabilities as reported in the balance sheets as of August 31, 2005 approximate their fair values because of the short maturity terms of these instruments other than the following financial instruments:

	<b>The Group</b>	
	<b>Carrying amount RM</b>	<b>Fair value RM</b>
<b>2005</b>		
<b>Financial Asset</b>		
Quoted investment (Note 11)	7,700	7,700
<b>Financial Liabilities</b>		
Hire-purchase payables (Note 17)	3,706,514	3,566,125
Term loans (Note 19)	7,905,829	6,834,702

The fair values of hire-purchase payables and term loans are estimated using the discounted cash flow analysis based on current borrowing rates for similar types of borrowing arrangements.

## 26. Capital Commitment

As of August 31, 2005, the Group has the following capital commitment:

	<b>The Group 2005 RM</b>
Approved and contracted for:	
Purchase of plant and machinery	<b>353,000</b>

## 27. Significant Events

In December 2004, the Company submitted an application to the Securities Commission pertaining to the listing of and quotation for its entire issued and paid-up share capital on the Second Board of Bursa Malaysia Securities Berhad which entails the following:

- (a) The acquisitions of:
- (i) the entire issued and paid-up share capital of Ban Seng Lee Industries Sdn. Bhd., comprising 15,000,000 ordinary shares of RM1.00 each for a purchase consideration of RM34,999,900, to be fully satisfied by the issuance of 69,999,800 new ordinary shares of the Company at an issue price of RM0.50 per share;
  - (ii) the entire issued and paid-up share capital of Unique Forging & Components Sdn. Bhd., comprising 400,000 ordinary shares of RM1.00 each for a purchase consideration of RM3,922,546, to be satisfied by the issuance of 2,824,000 new ordinary shares of the Company at an issue price of RM0.50 per share and cash consideration of RM2,510,546; and
  - (iii) the entire issued and paid-up share capital of Crestronics (M) Sdn. Bhd., comprising 1,700,000 ordinary shares of RM1.00 each for a purchase consideration of RM5,533,600, to be satisfied by the issuance of 1,106,000 new ordinary shares of the Company at an issue price of RM0.50 per share and cash consideration of RM4,980,600.

The abovementioned acquisitions were completed on April 28, 2005.

- (b) Implementation of a rights issue of 3,696,500 new ordinary shares of RM0.50 each at an issue price of RM0.50 each on a basis of one new ordinary share for every existing twenty shares held after the acquisitions of subsidiary companies as mentioned in (a) above.
- (c) Public issue of 20,373,500 new ordinary shares of RM0.50 each at an issue price of RM0.68 per share payable in full on application comprising:
- (i) 7,010,000 new ordinary shares of RM0.50 each available for application by the Malaysian public;
  - (ii) 6,470,000 new ordinary shares of RM0.50 each by way of private placement to certain identified investors;
  - (iii) 2,893,500 new ordinary shares of RM0.50 each to Bumiputera investors approved by the Ministry of International Trade and Industry; and
  - (iv) 4,000,000 new ordinary shares of RM0.50 each available for application by eligible directors, employees and business associates of the Company and its subsidiary companies.
- (d) Offer for sale of 6,988,200 new ordinary shares of RM0.50 each at an offer price of RM0.68 per share payable in full on application to Bumiputera investors approved by the Ministry of International Trade and Industry.

The listing has been approved by the relevant regulatory authorities on March 28, 2005 and on November 15, 2005, the entire issued and paid-up share capital of the Company comprising 98,000,000 ordinary shares of RM0.50 each was listed on the Second Board of BMSB.

# list of properties

62

BSL CORPORATION BHD • ANNUAL REPORT 2005

The details of the properties of the BSL Group as at 31 August 2005 are set out below:

Name of registered owner/ beneficial owner/ Location	Description/ Existing use	Land/ built-up area (sq. m.)	Approximate age of building (Years)	Tenure	Audited NBV as at 31 August 2005 (RM)	Date of valuation
BSLI Lot 47687 Jalan Bukit Idaman 6 Taman Bukit Idaman 68100 Batu Caves Selangor Darul Ehsan	Single storey detached factory with annexed 3 storey office building/ office and factory	7,067/ 5,909	12	Leasehold for 99 years expiring on 17 Oct 2089	7,187,806	9 Nov 2004
H.S. (M) 13569 Lot No. PT 22183 Mukim Batu Daerah Gombak Selangor Darul Ehsan						
BSLI Lot PT 12872 Nilai Industrial Area Nilai, Negeri Sembilan	Manufacturing/ Industrial land/ vacant	21,827/ -	-	Leasehold for 99 years expiring on 22 Aug 2095	2,969,697	10 Nov 2004
H.S. (D) 107769 Lot No. PT 12872 Mukim Labu Daerah Seremban Negeri Sembilan						
BSLI No. 12214 Jalan BBN 1/1G Putra Point Bandar Baru Nilai 71800 Nilai Negeri Sembilan	3 storey terrace shopoffice/ vacant	167/502	6	Freehold	274,400	10 Nov 2004
H.S. (D) 92294, PT 12214 Mukim Labu Daerah Seremban Negeri Sembilan						
BSLI 36A, 1st Floor Jalan Bukit Idaman 8/1 Taman Bukit Idaman 68100 Batu Caves Selangor Darul Ehsan	1 unit of apartment located on the 1st floor of 2½ storey intermediate shop apartment/ workers' hostel	Not applicable/ 120	11	Leasehold for 99 years expiring on 17 Oct 2089	98,000	9 Nov 2004
P.M. 293, Lot No. 52175 Mukim Batu Daerah Gombak Selangor Darul Ehsan						

Name of registered owner/ beneficial owner/ Location	Description/ Existing use	Land/ built-up area (sq. m.)	Approximate age of building (Years)	Tenure	Audited NBV as at 31 August 2005 (RM)	Date of valuation
BSLI 37A, 1st Floor Jalan Bukit Idaman 8/1 Taman Bukit Idaman 68100 Batu Caves Selangor Darul Ehsan  P.M. 294, Lot No. 52176 Mukim Batu Daerah Gombak Selangor Darul Ehsan	1 unit of apartment located on the 1st floor of 2½ storey intermediate shop apartment/ workers' hostel	Not applicable/ 120	11	Leasehold for 99 years expiring on 17 Oct 2089	98,000	9 Nov 2004
BSLI 35A, 1st Floor Jalan Bukit Idaman 8/1 Taman Bukit Idaman 68100 Batu Caves Selangor Darul Ehsan  P.M. 292, Lot No. 52174 Mukim Batu Daerah Gombak Selangor Darul Ehsan	1 unit of apartment located on the 1st floor of 2½ storey intermediate shop apartment/ workers' hostel	Not applicable/ 120	11	Leasehold for 99 years expiring on 17 Oct 2089	98,000	9 Nov 2004
BSLI 32A, 1st Floor Jalan Bukit Idaman 8/1 Taman Bukit Idaman 68100 Batu Caves Selangor Darul Ehsan  P.M. 289, Lot No. 52171 Mukim Batu Daerah Gombak Selangor Darul Ehsan	1 unit of apartment located on the 1st floor of 2½ storey intermediate shop apartment/ workers' hostel	Not applicable/ 120	11	Leasehold for 99 years expiring on 17 Oct 2089	98,000	9 Nov 2004
BSLI Lot 17513, Jalan 2 Selayang Industrial Park 68100 Batu Caves Selangor Darul Ehsan  Geran No. 29087 Lot No. 17513 Mukim Batu Daerah Gombak Selangor Darul Ehsan  Geran No. 29078 Lot No. 17508 Mukim Batu Daerah Gombak Selangor Darul Ehsan	Single storey detached factory/ manufacturing/ factory	2,926/ 2,364	11	Freehold	4,485,486	9 Nov 2004



# list of properties

Name of registered owner/ beneficial owner/ Location	Description/ Existing use	Land/ built-up area (sq. m.)	Date of issuance of certificate of fitness	Approximate age of building (Years)	Tenure	Audited NBV as at 31 August 2005 (RM)	Market value (RM)/ Date of valuation
Crestronics Lot 5002 Batu 5 <sup>1/2</sup> Jalan Meru 41050 Klang Selangor Darul Ehsan	Manufacturing/ Industrial/ office and factory	10,906/ 6,651	16 Jun 1989, 14 Jan 1991 and 18 Feb 1991	15	Freehold	5,328,672	30 Nov 2004
H.S. (M) 21401 PT 13725 Mukim Kapar Daerah Klang Selangor Darul Ehsan							

Authorised Share Capital:	RM250,000,000
Issued and Paid-up Capital:	RM49,000,000
Type of shares:	Ordinary of RM0.50 each
Voting Rights:	One vote per ordinary share

## Distribution of Shareholdings

Holdings	No. of Holders	%	Total Holdings	%
Less than 100	1	0.19	50	0.00
100 to 1,000	157	29.07	125,810	0.13
1,001 to 10,000	253	46.85	1,279,512	1.31
10,001 to 100,000	76	14.07	2,687,792	2.74
100,001 to 4,899,999*	50	9.26	32,459,599	33.12
4,900,000 and above **	3	0.56	61,447,237	62.70
	<b>540</b>	<b>100.00</b>	<b>98,000,000</b>	<b>100.00</b>

Note:

\* Less than 5% of Issued Shares

\*\* 5% and above of Issued Shares

## List of Substantial Shareholders

Name	Direct Shareholdings		Indirect Shareholdings (exclude bare trustees)	
	No. of shares	%	No. of shares	%
Esteem Role Sdn Bhd	49,980,000	51.00	–	–
Ngiam Tong Kwan	406,315	0.41	49,980,000 <sup>(*)</sup>	51.00
Nyeam Tong Eng @ Ngiam Tong Yang	269,361	0.27	49,980,000 <sup>(*)</sup>	51.00
Teh Eng Hock	269,361	0.27	49,980,000 <sup>(*)</sup>	51.00
Dato' Hamzah Bin Mohd Salleh	12,667,237	12.92	–	–

## List of Directors' Shareholdings

Name	Direct Shareholdings		Indirect Shareholdings	
	No. of shares	%	No. of shares	%
Ngiam Tong Kwan	406,315	0.41	49,980,000 <sup>(*)</sup>	51.00
Ngiam Tee Wee	135,000	0.14	–	–
Ngiam Tee Yang	100,000	0.10	–	–
Teh Yoon Loy	36,347	0.04	–	–
Yukihiro Eguchi	58,445	0.06	–	–
Dato' Hamzah Mohd Salleh	12,667,237	12.92	–	–
Gan Leng Swee	40,000	0.04	–	–
Dato' Kalsom Abdul Rahman	1,530,000	1.56	–	–
Chong Ai Wan	60,000	0.06	–	–

(\*) Deemed interest though the substantial shareholding in Esteem Role Sdn Bhd pursuant to Section 6A(4) of the Companies Act, 1965.

# analysis of shareholdings

as at 6 January 2006

66

BSL CORPORATION BHD • ANNUAL REPORT 2005

## List of Top 30 Shareholders

No.	Name of Shareholders	Shareholdings	%
1	Esteem Role Sdn Bhd	49,980,000	51.00
2	RHB Capital Nominees (Tempatan) Sdn Bhd <i>Pledged Securities Account for Hamzah Bin Mohd Salleh (BSL)</i>	6,467,237	6.60
3	EB Nominees (Tempatan) Sendirian Berhad <i>Pledged Securities Account for Hamzah Bin Mohd Salleh (SFC)</i>	5,000,000	5.10
4	HDM Nominees (Tempatan) Sdn Bhd <i>Johar Bin Murat @ Murad</i>	3,000,000	3.06
5	CIMSEC Nominees (Asing) Sdn Bhd <i>Exempt AN For CIMB-GK Securities Pte Ltd (Retail Clients)</i>	1,515,000	1.55
6	HDM Nominees (Tempatan) Sdn Bhd <i>Pledged Securities Account for Mohd Suhaimi Bin Hashim (M10)</i>	1,500,000	1.53
7	RHB Capital Nominees (Tempatan) Sdn Bhd <i>Pledged Securities Account for Kalsom Binti Abd Rahman (BSL)</i>	1,470,000	1.50
8	Nik Fauzi Bin Nik Hussein	1,423,500	1.45
9	HDM Nominees (Tempatan) Sdn Bhd <i>Pledged Securities Account for Goh Hoon Ghee (M12)</i>	1,383,000	1.41
10	AmBank (M) Berhad <i>Pledged Securities Account for Hamzah Bin Mohd Salleh (SMART)</i>	1,200,000	1.22
11	S'ng King Kiok	1,062,700	1.08
12	Nada Jelata Sdn Bhd	1,040,000	1.06
13	Goh Hoon Ghee	1,020,000	1.04
14	EB Nominees (Tempatan) Sendirian Berhad <i>Pledged Securities Account for Ariffin Bin Morad (SFC)</i>	1,000,000	1.02
15	EB Nominees (Tempatan) Sendirian Berhad <i>Pledged Securities Account for Azmi Bin Mahamad (SFC)</i>	1,000,000	1.02
16	Sharifah Rohaizah Binti Syed Abu Bakar	953,000	0.97
17	RHB Nominees (Tempatan) Sdn Bhd <i>Pledged Securities Account for Woo Yam Sang</i>	946,000	0.97
18	CIMSEC Nominees (Tempatan) Sdn Bhd <i>CIMB-Principal Asset Management Berhad for Lembaga Tabung Haji</i>	900,000	0.92
19	Kumpulan Modal Perdana Sdn Bhd	735,200	0.75
20	Mayban Nominees (Tempatan) Sdn Bhd <i>Mayban Trustees Berhad for Lifetime Dana Barakah (230122)</i>	700,000	0.71
21	Sharon Ng Beng Beng	693,500	0.71
22	Woo Yam Sang	688,700	0.70
23	Kong Chun Wah	680,000	0.69
24	Loke Keng Hung	642,500	0.66
25	Phua Swee Fang	632,000	0.64
26	Mayban Securities Nominees (Tempatan) Sdn Bhd <i>Pledged Securities Account for Yee Foong Seng (REM 646)</i>	568,000	0.58
27	Mayban Securities Nominees (Asing) Sdn Bhd <i>Pledged Securities Account for Ong Hian Eng (39B)</i>	500,000	0.51
28	Mayban Securities Nominees (Tempatan) Sdn Bhd <i>Pledged Securities Account for Yee Foong Seng (REM 646-Margin)</i>	500,000	0.51
29	S'ng Shew Kim	430,000	0.44
30	Lim Leng Na	407,000	0.42
		<b>88,037,337</b>	<b>89.82</b>

# proxy form



I/We \_\_\_\_\_  
of \_\_\_\_\_  
being a member/members of **BSL CORPORATION BERHAD** hereby appoint \*the Chairman of the meeting  
or \_\_\_\_\_  
of \_\_\_\_\_  
or failing him \_\_\_\_\_  
of \_\_\_\_\_

as \*my/our proxy/proxies to attend and vote for \*me/us and on \*my/our behalf at the 2nd Annual General Meeting of the Company to be held at the Subang 2, Sheraton Subang Hotel, Jalan SS12/1, 47500 Subang Jaya, Selangor Darul Ehsan on Wednesday, 22 February 2006 at 10.30 a.m. and at any adjournment thereof, and to vote as indicated below:

Resolutions	For	Against
<b>Ordinary Business</b>		
1. Receive the Audited Financial Statements for financial year ended 31 August 2005.		
2. Re-election of Ngiam Tong Kwan as Director		
3. Re-election of Ngiam Tee Wee as Director		
4. Re-election of Dato' Hamzah Bin Mohd Salleh as Director		
5. Re-election of Dato' Kalsom Binti Abdul Rahman as Director		
6. Re-election of Ngiam Tee Yang as Director		
7. Re-election of Teh Yoon Loy as Director		
8. Re-election of Yukihiro Eguchi as Director		
9. Re-election of Gan Leng Swee as Director		
10. Re-election of Chong Ai Wan as Director		
11. Approval of Directors' Fees		
12. Re-appoint Messrs Deloitte KassimChan		
<b>Special Business</b>		
13. Authority to the Directors to issue shares pursuant to Section 132D of the Companies Act, 1965		

(Please indicate with an "X" in the space provided above on how you wish your vote to be cast. If you do not do so, the proxy will vote or abstain from voting at his discretion)

Dated this \_\_\_\_\_ day of \_\_\_\_\_ 2006.

No of shares held

Signature or Common Seal of Member(s)

*\*Delete whichever is not applicable*

#### Notes:

- A member (other than an Authorised Nominee as defined under the Securities Industry (Central Depositories) Act 1991) entitled to attend and vote at the Meeting is entitled to appoint a maximum of two Proxies to attend and vote on his (her) behalf. A proxy may but need not be a member of the Company and the provisions of section 149(1)(b) of the Companies Act, 1965 shall not apply to the Company.
- Where a member appoints two (2) Proxies, the appointment shall be invalid unless he (she) specifies the proportions of his (her) holdings to be represented by each Proxy.
- The Proxy Form shall be signed by the appointor or his (her) attorney duly authorised in writing or, if the member is a corporation, must be executed under its common seal or by its duly authorised attorney or officer
- The instrument appointing a Proxy must be deposited at the registered office at Level 14, Uptown 1, No. 1, Jalan SS21/58, Damansara Uptown, 47400 Petaling Jaya, Selangor Darul Ehsan, not less than 48 hours before the time for the meeting or at any adjournment thereof.

---

Stamp

To:

**The Company Secretary**  
**BSL Corporation Berhad**

Level 14, Uptown 1  
No. 1, Jalan SS 21/58  
Damansara Uptown  
47400 Petaling Jaya  
Selangor Darul Ehsan

---